

WTR WESTCHESTER TOOL RENTALS

EQUIPMENT RENTALS
RENTALS • SALES • SERVICE
CONTRACTOR • HOMEOWNER



wtrrentals.com

11 VREELAND AVE ELMSFORD • 914-592-2016
1075 WASHINGTON ST PEEKSKILL • 914-739-9000

CONSTRUCTION EQUIPMENT

Since 1983

2026-2027



914-592-2016 | 914-739-9000
OPEN MONDAY - SATURDAY 7 TO 5

NO TRUCK? NO TIME?
NO PROBLEM! WE DELIVER!

To Our Customers...

It is our goal that our catalog will help guide you in the selection of the tools and equipment you need. Please keep in mind this catalog does not represent our total inventory. It is a small depiction of the hundreds of new and used items we have available. So if you don't see what you need please give us a call, we probably have it, but if not we can get it for you. Sincerely, Karin Puff, President Westchester Tool Rentals.

SOME THINGS YOU SHOULD KNOW

Hours

7:00 am—5:00pm Monday thru Friday

7:00am—3:00pm Saturday *Seasonally*

Closed Sundays and Major Holidays

(Sunday and Holiday rentals available)

These are abbreviated terms - Full terms and conditions can be found on the rental contract and our website.

Rental Day

The rental day is based on an 8 hour period. Any equipment used double shift will be charged one and a half times the daily rate; triple shift two times the rate. Special arrangements can be made for 5:00 p.m. pick ups for the next day rentals. Equipment is charged for time out, not time used. Come early for maximum use/greatest value!

Sunday & Holidays

A one-day minimum charge applies to all tools picked up on the eve before the holiday and returned by 8:00 a.m. the next business day. If the tool is used for two days, the two day charge applies.

Overtime Charges

Overtime charges will be assessed for equipment not returned on time. Arrangements for late returns must be approved as equipment due back is often scheduled for rental.

Long Term Rentals

Call for more information.

Terms & Conditions

A cash deposit and/or a major credit card is taken on all rentals and varies depending on the rentals rate and length of rentals. Adequate identification is required for all rentals.

Open Account

No Truck? No Time? No Problem!

We Deliver to Your Door or Job!

Open Monday to Friday 7am—5pm

Open Saturday 7am-3pm

914-592-2016 Elmsford

914-739-9000 Peekskill

Credit may be extended to select accounts with a completed application. Terms are net 30; past due accounts will be closed.

Delivery Rates

Delivery is available for larger rental equipment and is charged based upon location. Rental time begins when equipment leaves our premises. Customer must call to schedule a pick up. A pick up number will be given to document the call and time equipment is taken off rental. All rental items remain on rental until a pick up is scheduled. We do not automatically pickup equipment at the end of the work day.

Customer is responsible for all items until they are picked up.

Fuel

Customer pays for all fuel used. All equipment is rented full of fuel and must be returned full or a refueling charge will be applied.

Reservations

We will gladly reserve equipment in advance whenever possible. If for any reason a reservation cannot be kept it is the obligation of the customer to call no later than 8:00 am on the day of the reservation. These terms must be met or a one day charge will be billed and future reservations will not be honored.

Loss

In the event equipment is lost or stolen customer will be billed for replacement cost plus accrued rental charges to time of notification.

Damage Waiver

Customers may obtain our damage waiver on most equipment for a charge of 12% of the rental. This waiver covers 80% of the repair cost and limits the customer to 20% of the replacement cost of equipment damaged beyond repair. Damage waiver does not cover abuse, theft or lost parts.

Ready for Rental

All equipment is inspected, tested and operated before leaving our premises to verify good working order. A charge will be assessed for any items returned damaged, with excessive wear, or exceptionally dirty.

**Hydraulic Hoses Made
While-U-Wait**



Dig! Safely, New York
Call 811
before you dig



TABLE OF CONTENTS:



4-9

CONTRACTOR



9-13

**CONCRETE
EQUIPMENT**



14-15

**FLOOR CARE
SURFACE PREP**



16-17

**COOLING
HEATING**



18-24

**LAWN &
GARDEN**



25

**UTVS
GROUND HEATER**



26-28

**GENERATORS &
POWER DISTRO.**



29

**AIR
COMPRESSORS**



30-35

**EARTH
MOVING**



36

**TRAILERS &
DUMP TRUCK**



37

COMPACTION



38-39

**AERIAL
SCISSOR LIFTS**



40-41

**ARTICULATED
STRAIGHT BOOMS**



42-45

**MATERIAL
HANDLING**



46-48

**SCAFFOLDING
& LADDERS**



49

**PRESSURE
WASHERS**



50-51

PLUMBING



52-54

POWER TOOLS



55

PUMPS



56-57

MISC.



58

**WELDING
SUPPLIES**



59-65

PARTY PAGES



914-592-2016 | 914-739-9000
OPEN MONDAY - SATURDAY 7 TO 5

NO TRUCK? NO TIME?
NO PROBLEM! WE DELIVER!



#602 MASONRY SAW 47"
WET | 14" BLADE INCL.
\$195 DAY | \$585 WK



#147 BLOCK SAW
WET | 14" BLADE INCL.
\$100 DAY | \$395 WK



#603 DRI-CUT BLOCK CUTTER
DRY | 14" BLADE INCL.
\$116 DAY | \$464 WK



#601 TILE SAW 24"
WET | 10" BLADE INCL.
\$110 DAY | \$440 WK



#70 CORE DRILL RIG
ELEC. 2" TO 14" CAPACITY
\$125 DAY | \$375 WK



#71 CORE DRILL VACUUM
ELEC. | GASKETS INCL.
\$23 DAY | \$92 WK



#72 CORE DRILL
HAND HELD | ELEC. | 3" CAP.
\$90 DAY | \$360 WK



#649 HAND WATER PUMP TANK
PORTABLE | HAND HELD
\$15 DAY | \$45 WK



**CORE BITS
AVAILABLE TO RENT & BUY**



#335 INSULATION BLOWER
INCL. 100' OF HOSE
\$88 DAY | \$352 WK



#335 INSULATION BLOWER
INCL. 100' OF HOSE
\$88 DAY | \$352 WK



#347 STUD GUN
SINGLE SHOT | .22 LV
\$33 DAY | \$132 WK

#348 STUD GUN
10 SHOT | .27 LV
\$40 DAY | \$120 WK



#140 SHEETROCK LIFTER
11' TILTING | UP TO 12' LONG
\$46 DAY | \$184 WK



#137 SHEETROCK DOLLY
3,000 LB CAP.
\$20 DAY | \$60 WK



#337 DRYWALL SANDER/VACUUM
SANDER & VACUUM IN ONE
\$66 DAY | \$264 WK



#334 HEPA AIR SCRUBBER
(FILTERS SOLD SEPARATELY)
\$35 DAY | \$140 WK

"NEGATIVE AIR"



CALL TODAY FOR MONTHLY RATE!

#848 ROTARY HAMMER
CORDLESS | 20V | 1" SDS MAX KIT
\$40 DAY | \$120 WK



#93 POST / STAKE DRIVER
44 LB | GAS
\$83 DAY | \$332 WK



#90 DEMO HAMMER
50 LB | HILTI BITS | ELECTRIC
\$80 DAY | \$320 WK

#95 PAVEMENT BREAKER *
HAMMER | 28 LB | HILTI TE
\$90 DAY | \$360 WK

#94 DEMO HAMMER
68 LB | 1-1/8" STEEL | ELECTRIC
\$100 DAY | \$395 WK

Gas - 2 cycle



#283 CUT OFF SAW *
14" | 2 CYCLE | GAS
\$80 DAY | \$320 WK



#40 ROTARY HAMMER DILL
CHIPPING DRILL 2" | SDS
\$80 DAY | \$320 WK

#91 ROTARY HAMMER DRILL
CHIPPING DRILL 1-1/2" | SDS
\$55 DAY | \$220 WK

**WE SELL & RENT
DIAMOND BLADES!**

Gas - 2 cycle



DRILL BITS SDS & TE
***FOR SALE OR RENT**



#284 DIAMOND CHAIN SAW *
14" | 2 CYCLE | GAS
\$145 DAY | \$580 WK



#287 HILTI VACUUM
9.5 GAL CAPACITY
\$72 DAY | \$288 WK



#286 HILTI CUT-OFF SAW *
12" | UP TO 4-3/4" | ELEC
\$60 DAY | \$240 WK



914-592-2016 | 914-739-9000
OPEN MONDAY - SATURDAY 7 TO 5

**NO TRUCK? NO TIME?
NO PROBLEM! WE DELIVER!**



#1530 MAN HOLE LIFT
 CONFINED SPACE LIFT
 \$85 DAY | \$340 WK



#370 VENTILATION BLOWER
 GAS | 8" DUCT
 \$46 DAY | \$185 WK



#371 VENTILATION BLOWER
 ELECTRIC | 8" DUCT
 \$53 DAY | \$211 WK



#565 VENTILATION BLOWER
 ELECTRIC | 12" DUCT
 \$53 DAY | \$212 WK



#4 AIR COMPRESSOR
 15.4 CFM GAS
 \$53 DAY | \$208 WK



#3 AIR COMPRESSOR
 7.3 CFM | ELECTRIC
 \$46 DAY | \$184 WK



#2 AIR COMPRESSOR
 4.2 CFM | ELECTRIC
 \$35 DAY | \$140 WK



#570 BUILDERS LEVEL
 AUTOMATIC
 \$50 DAY | \$200 WK



#138 TRANSIT / LEVEL
 \$46 DAY | \$184 WK



#139 LASER LEVEL
 EXTERIOR | W/ RECEIVER
 \$57 DAY | \$229 WK



#121 POST SHORING JACK
 ADJ. 7' - 11'
 \$13 DAY | \$26 WK



#120 SCREW JACK
 20 TON
 \$15 DAY | \$30 WK



#126 BOTTLE JACK
 20 TON | HYDRAULIC
 \$23 DAY | \$46 WK



#846 LASER GREEN LIGHT LEVELER
20V | 230' RANGE
\$40 DAY | \$120 WK



#423 DRILL
20V
\$18 DAY | \$54 WK



#844 DEWALT BATTERY BUFFER
7" VARI SPEED | 20V
\$25 DAY | \$75 WK



#22 DEWALT IMPACT DRIVER
1/2" | 20V
\$20 DAY | \$80 WK



#848 DEWALT HAMMER DRILL
1" SDS MAX KIT | 20V
\$11 DAY | \$44 WK



#841 FINISH NAILER
20V | ANGLED
\$40 DAY | \$120 WK



#840 FRAMING NAILER
20V
\$69 DAY | \$277 WK



#668 FLOOR SCRUBBER *
15" BRUSH | BATTERY
\$92 DAY | \$368 WK



#667 FLOOR SCRUBBER *
DUEL HEAD | BATTERY
\$185 DAY | \$740 WK

CALL TODAY FOR MONTHLY RATE!



#875 MINI EXCAVATOR 5'-2"
RUBBER TRACK
\$385 DAY | \$1540 WK



#865 PLATE COMPACTOR
17" | BATTERY OPERATED
\$110 DAY | \$440 WK



#1550 HILTI CUT OFF SAW
BATTERY OPERATED
12" X 1" | 4 3/4" CUT
\$50 DAY | \$200 WK



#1560 CHAINSAW KIT
16" | BATTERY KIT
2 BATTERIES & CHARGER
\$75 DAY | \$300 WK



#1561 CHAINSAW KIT
20" | BATTERY KIT
2 BATTERIES & CHARGER
\$80 DAY | \$320 WK



914-592-2016 | 914-739-9000
OPEN MONDAY - SATURDAY 7 TO 5

NO TRUCK? NO TIME?
NO PROBLEM! WE DELIVER!



#426 LIGHT TOWER W/GENERATOR
 4 LIGHT | 4000 WATT | DIESEL
\$176 DAY | \$440 WK

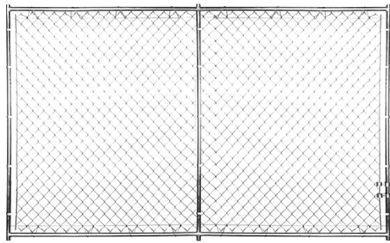

#596 TEMPORARY FENCE
 8' X 8' PANEL
\$13 WK | \$33 MO



#599 BASE PLATE
 FOR TEMPORARY FENCE
\$6 WK | \$11 MO

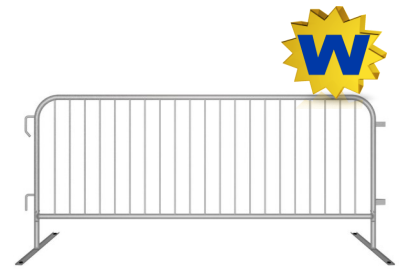

#589 TEMPORARY FENCE
 8' "BIKE RACK"
\$29 DAY | \$43 WK



#860 DURA-DECK
 PLASTIC PROTECTIVE MATTING
 4' X 8' X 1/2"
 USE IN PLACE OF PLYWOOD
\$11 DAY | \$28 WK

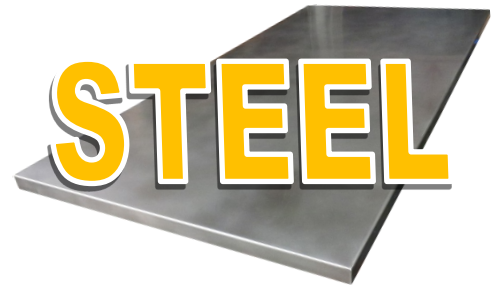

#480 ROAD PLATE
 5' X 10' | 1" THICKNESS
\$100 WEEK | \$300 MO

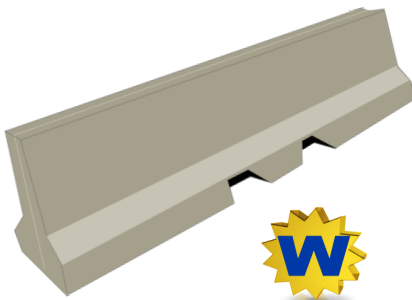

#1220 JERSEY BARRIER
 20' | 8,000 #
\$200 WK | \$400 MO

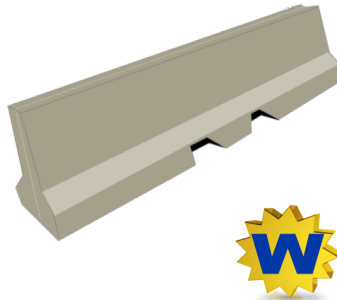

#1221 JERSEY BARRIER
 10' | 4,000 #
\$165 WK | \$330 MO



#1223 JERSEY BARRIER
 LIFTING GRAB
\$55 DAY | \$220 WK



#1214 WATER FILLED BARRIERS
 6' | PLASTIC
\$45 WK | \$80 MO

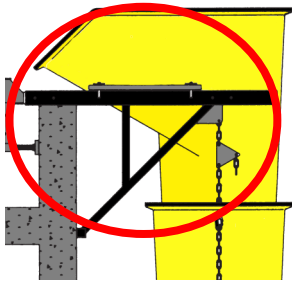

#519 PARAPIT OUTRIGGER TRASH HOPPER BRACKET ONLY
\$13 DAY | \$26 WK



#522 WINDOW HOPPER TRASH CHUTE
\$33 DAY | \$66 WK

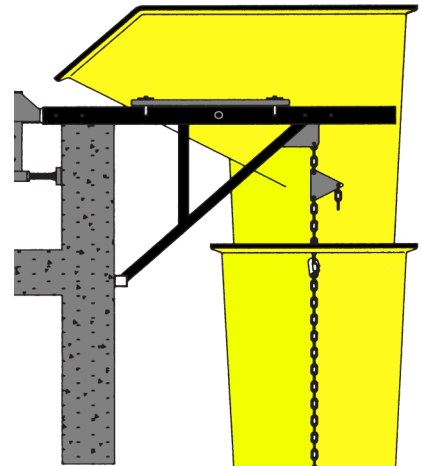

SAMPLE TRASH CHUTE

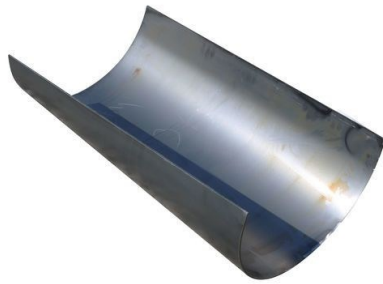

#521L TRASH CHUTE LINER METAL | 4'
\$13 DAY | \$26 WK



#521 TRASH CHUTE 30" X 4'
\$28 DAY | \$56 WK

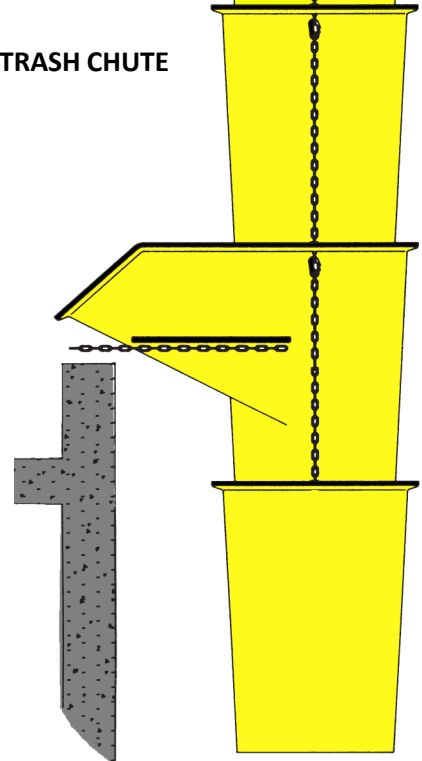

#518 TRASH CHUTE WINCH KIT
\$66 DAY | \$198 WK

CALL TODAY FOR MONTHLY RATE!



#428 ARROW BOARD 25 LIGHT
\$138 DAY | \$414 WK

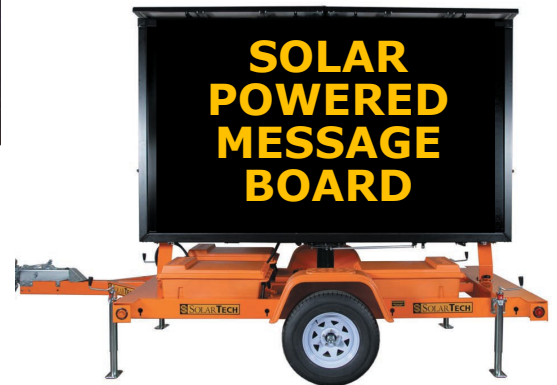

#427 MESSAGE BOARD 126" X 76" FULL MATRIX
\$260 DAY | \$780 WK



914-592-2016 | 914-739-9000
OPEN MONDAY - SATURDAY 7 TO 5

NO TRUCK? NO TIME?
NO PROBLEM! WE DELIVER!

CONCRETE EQUIP



#46 CONCRETE SAW*
14" | GAS | PUSH
\$95 DAY | \$380 WK



#392 ELECTRIC SAW*
18" | 5 HP 220V | 1 PHASE
\$150 DAY | \$600 WK



#45 CONCRETE SAW*
24" SELF PROPELLED | 20HP
\$185 DAY | \$740 WK



#550 ROAD SAW*
30" | SELF PROPELLED | 35HP GAS
\$325 DAY | \$1,430 WK



#283 CUT-OFF SAW*
14" GAS | 2 CYCLE
\$80 DAY | \$320 WK



#286 CUT-OFF SAW*
12" | ELECTRIC | 110 VOLT
\$60 DAY | \$240 WK



CHAINS ARE A SALE ITEM
#284 DIAMOND CHAIN*
14" | 2 CYCLE | GAS
\$145 DAY | \$580 WK



#444 REBAR CUTTER
BENDER HAND
\$29 DAY | \$87 WK

*** DIAMOND BLADES & CHAINS ARE FOR SALE OR RENT! CALL FOR MONTHLY RATES!**

Supplies Available by the Bag or Pallet!



We Sell, Service and Repair Your Favorite Brands



We have a huge selection of

Diamond Blades & Core Bits

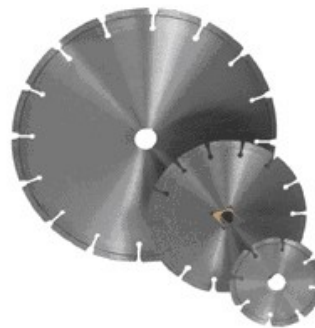

CALL TODAY FOR
MONTHLY RATE!



#36 TRACK BUGGY
16 CU. FT. GAS | RIDE-ON
\$210 DAY | \$840 WK



#37 TRACK BUGGY
16 CU FT PIVOT DUMP | GAS | RIDE-ON
\$230 DAY | \$920 WK



#661 ELECTRIC REBAR CUTTER
#3 TO #8
\$66 DAY | \$198 WK



#49 CONCRETE MIXER
3 CU. FT. | ELECTRIC
\$48 DAY | \$192 WK



#53 CONCRETE MIXER
9 CU. FT. | 1-1/2 BAG | GAS
\$90 DAY | \$360 WK



#54 MORTAR MIXER
1-1/2 BAG | 9 CU. FT. | GAS
\$88 DAY | \$352 WK



#660 ELECTRIC REBAR BENDER
#3 TO #8
\$165 DAY | \$495 WK



#52 GAS VIBRATOR
BACKPACK | 10' SHAFT
\$77 DAY | \$308 WK



#50 PENCIL VIBRATOR
3/4" HEAD | 9' SHAFT
\$57 DAY | \$228 WK



#48 CONCRETE VIBRATOR
2" HEAD | 14' SHAFT
\$64 DAY | \$256 WK



#35 CONCRETE CHUTE
12' ALUMINUM
\$18 DAY | \$54 WK



#544 BULL FLOAT
8" X 48" ADJ. PITCH | 6' HANDLES
\$30 DAY | \$90 WK



#51 POWER SCREED
1 MAN | 10' / 12'
\$92 DAY | \$368 WK



#47 POWER TROWEL *
36" | 4 BLADE | GAS
\$92 DAY | \$368 WK

* FLOAT BLADES AVAILABLE



914-592-2016 | 914-739-9000
OPEN MONDAY - SATURDAY 7 TO 5

NO TRUCK? NO TIME?
NO PROBLEM! WE DELIVER!

SURFACE PREP ACCESSORIES



#80 BUFFER 16"
\$42 DAY | \$167 WK



#943 FLOOR SCRAPER
FOR ELECTRIC HAMMERS
\$20 DAY | \$60 WK



#80CS TCAD
\$40 DAY | \$120 WK



#80HW DIAMA BRUSH
HARDWOOD SCRAPER
\$88 DAY | \$352 WK

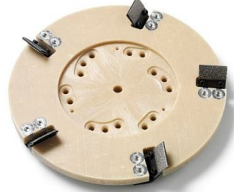

#80MR DIAMA BRUSH
MASTIC REMOVAL
\$110 DAY | \$330 WK



#80CP DIAMA BRUSH
CONCRETE PREP BRUSH
\$88 DAY | \$352 WK



#80DD DRIVER DISK
\$22 DAY | \$66 WK



#586 DIAM-A-TACH DIAMOND
SEGMENT GRINDING SYSTEM
\$50 DAY | \$150 WK EACH

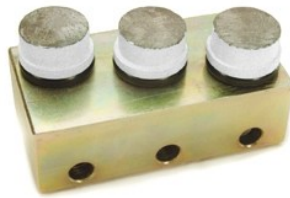

#587 DIAM-A-TACH DIAMOND
SEGMENT GRINDING SYSTEM
\$50 DAY | \$150 WK EACH



#235 SCRAPER FLOOR INSERT
\$15 DAY | \$45 WK EACH

ATTACHMENT	GRIND CONCRETE FLOORS	ROUGHEN CONCRETE FLOORS	REMOVE THINSET	CLEAN CONCRETE FLOORS	REMOVE MATERIAL BUILD-UP	REMOVE FLOOR EPOXIES	REMOVE FLOOR PAINT	REMOVE FLOOR URETHANE	GRIND ASPHALT SURFACE
	✓	✗	✗	✓	✗	✓	✓	✓	✓
	✓	✗	✗	✓	✗	✓	✓	✓	✓
	✗	✗	—	✗	✓	✓	✓	✓	✗

Preferred Method
 Acceptable Performance
 Limited Performance

**50 TO 800 GRIT
AVAILABLE FOR SALE
DIAMOND POLISHING
PADS NOT INCLUDED**



#584 FLOOR GRINDER *
SINGLE HEAD | ELECTRIC
\$90 DAY | \$360 WK



#236 FLOOR GRINDER *
DUAL HEAD | 110 V | 30 AMP ELECTRIC
\$110 DAY | \$440 WK

**CALL TODAY
FOR
MONTHLY
RATE!**



#577 DUST COLLECTOR
110 V | ELECTRIC | 17 AMP
\$88 DAY | \$352 WK



#233 FLOOR GRINDER *
HD | DUAL HEAD | GAS
\$120 DAY | \$480 WK



#580 SURFACE PLANER 10" *
13 HP | GAS
\$140 DAY | \$560 WK



#75 FLOOR STRIPPER *
ELECTRIC | 110 V | 1 PHASE
\$80 DAY | \$320 WK



#583 SURFACE PLANER 8" *
ELECTRIC | 220V | 1 PHASE
\$100 DAY | \$400 WK



#237 SURFACE PLANER 8" *
5.5 HP | GAS
\$100 DAY | \$400 WK

*** BLADES SOLD OR RENTED SEPARATELY**

ATTACHMENT TYPE	VINYL TILE	LINOLEUM	RUBBER-BACKED CARPET	JUTE-BACKED CARPET	CERAMICTILE	MASTIC ADHESIVE	MEMBRANES	THIN SET	MATERIAL BUILD-UP
Mastic Removal	X	X	X	X	X	✓	X	X	✓
Dual Reveled	✓	X	X	X	X	X	X	X	X
Scoring	✓	✓	✓	✓	X	X	✓	X	X
Single Reveled	✓	X	X	X	X	X	X	X	X



#581 10" PLANER FLAIL CARBIDE BLADE KIT
\$140 DAY | \$560 WK

#582 8" PLANER FLAIL CARBIDE BLADE KIT
\$110 DAY | \$440 WK



914-592-2016 | 914-739-9000
OPEN MONDAY - SATURDAY 7 TO 5

**NO TRUCK? NO TIME?
NO PROBLEM! WE DELIVER!**



#669 FLOOR SCRUBBER 15"
 ROTARY BRUSH | 110 V
\$75 DAY | \$300 WK



#668 FLOOR SCRUBBER*
 15" BRUSH | BATTERY
\$92 DAY | \$368 WK



#667 FLOOR SCRUBBER*
 DUEL HEAD | BATTERY
\$185 DAY | \$740 WK



#627 FLOOR STEAMER
\$69 DAY | \$277 WK



#665 CARPET CLEANER*
 HOT WATER | 110 V | ELEC
\$75 DAY | \$300 WK



#329 CLEANER/EXTRACTOR*
 CARPETS & UPHOLSTERY
\$35 DAY | \$140 WK



#628 CARPET CLEANER*
 COMPACT WALK BEHIND
\$35 DAY | \$140 WK



**#327 UPHOLSTERY/
 STAIR ATTACHMENT**
\$11 DAY | \$44 WK



#342 HYDROXYL GENERATOR
 OCCUPANCY SAFER FOR ODOR
\$60 DAY | \$240 WK



#333 O-ZONE GENERATOR
 FOR ODOR REMEDIATION
\$57 DAY | \$228 WK



#307 FLOOD SUCKER
 VACUUM & PUMP
\$69 DAY | \$276 WK



#254 SHOP VACUUM*
 WET /DRY | 10 GAL.
\$40 DAY | \$158 WK



**180 CFM
 80 Pints**

#67 DEHUMIDIFIER
 HEAVY DUTY 15 GALLON
\$44 DAY | \$176 WK



**325 CFM
 130 Pints**

#336 DEHUMIDIFIER
 EXTRA HEAVY DUTY
\$60 DAY | \$240 WK



#330 TURBO DRYER
 110 VOLT | ELECTRIC
\$29 DAY | \$87 WK



#341 STUDEBAKER AIR MOVER
 110 VOLT | ELECTRIC
\$40 DAY | \$120 WK

"NEGATIVE AIR UNIT"



#334 AIR SCRUBBER*
 110V | 500
\$35 DAY | \$140 WK



#323 AIR SCRUBBER*
 110V | 400
\$25 DAY | \$100 WK



**#292 CARPET STRETCHER
 POWER KIT**
\$44 DAY | \$132 WK



**#55 CARPET
 KNEE KICKER**
\$17 DAY | \$33 WK



#325 CARPET IRON*
 110 VOLT | ELECTRIC
\$24 DAY | \$72 WK

SAND PAPER CLEANING AND FINISHING PRODUCTS FOR SALE



#01 SANDER & EDGER KIT
\$95 DAY | \$380 WK



FLOOR AND CARPET



#77 PNEUMATIC FLOOR NAILER*
2" T-NAILS
\$45 DAY | \$180 WK



#68 UNDER RADIATOR
FLOOR SANDER*
\$35 DAY | \$140 WK



#76 FLOOR SANDER*
EDGER 7"
\$36 DAY | \$144 WK



#81 FLOOR DRUM SANDER*
8" WIDE | VELCRO PAPER
\$66 DAY | \$264 WK



#79 FACE NAILER*
HARDWOOD FLOORS | 2" T-NAILS
\$33 DAY | \$132 WK



#78 FLOOR NAILER*
2" T-NAILS
\$33 DAY | \$132 WK



#326 ORBITAL FLOOR*
SANDER/BUFFER/POLISHER
\$66 DAY | \$264 WK



#80 FLOOR BUFFER 16"*
ATTACHMENTS AVAILABLE
\$42 DAY | \$167 WK



#65 LAMINATE STAPLER*
3/8 STAPLER
\$35 DAY | \$140 WK



#104 LINOLEUM ROLLER
\$18 DAY | \$72 WK

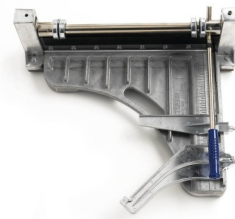

#57 FLOOR TILE VINYL CUTTER 12"
\$23 DAY | \$69 WK

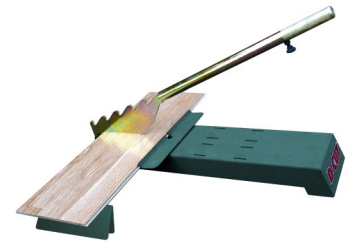

#297 LAMINATE CUTTER
13" CAPACITY
\$23 DAY | \$69 WK



#324 CARPET STAPLER
\$18 DAY | \$54 WK



#149 TILE SAW
WET | 7" BLADE INCL.
\$44 DAY | \$176 WK



#148 TILE SAW
WET | 10" BLADE INCL.
\$80 DAY | \$320 WK



#601 TILE SAW 10"
WET | 24" CAP. | BLADE INCL.
\$110 DAY | \$440 WK

* RELATED ITEMS FOR SALE



914-592-2016 | 914-739-9000
OPEN MONDAY - SATURDAY 7 TO 5

NO TRUCK? NO TIME?
NO PROBLEM! WE DELIVER!

CALL TODAY FOR MONTHLY RATE!



1 hp



1/3 hp



#2088 EVAPORATIVE COOLER
1 HP | OSCILLATING | 110V
\$220 DAY | \$440 WK

#2087 EVAPORATIVE COOLER
1/3 HP | OSCILLATING | 110V
\$165 DAY | \$330 WK

#171 PEDESTAL FAN 24"
\$35 DAY | \$105 WK

#172 FLOOR FAN 42"
\$46 DAY | \$138 WK



NARROW

NARROW

#2131 AIR CONDITIONING
1.5 TONS | 110 V | 20 AMPS
\$121 DAY | \$363 WK

#2113 AIR CONDITIONING
5 TON | 220 V | 3 PHASE
\$462 DAY | \$1,270 WK

#2114 AIR CONDITIONING
12 TON | 220 V | 3 PHASE
\$600 DAY | \$1,800 WK

#2104 AIR CONDITIONING
20 TON | 220 V | 3 PHASE
\$1,650 DAY | \$3,300 WK



#2112 AIR CONDITIONING
20 TON | 460 V | 3 PHASE
\$1,848 DAY | \$2,722 WK

#2166 18" DUCT
\$30 DAY | \$45 WK

#2162 14" DUCT
\$28 DAY | \$42 WK

#811 12" DUCT
\$20 DAY | \$30 WK

AIR CONDITIONED TENTS

Training | Seminars | Safety Courses | Appreciation Events

We Sell Kerosene & Propane

CALL TODAY FOR MONTHLY RATE!

K1 KEROSENE BY THE GALLON



HEATING

ELECTRIC



#2119 60 KW HEATER
205,000 BTU | 480V
3 PHASE | 75 AMP
\$360 DAY | \$900 WK



3 Phase

#98 HEATER
220V | 50 AMP | 61K BTU
\$92 DAY | \$276 WK



1 Phase

#790 HEATER
220V | 50 AMP | 30K BTU
\$46 DAY | \$138 WK



#96 HEATER
110V | 15 AMP | 5,100 BTU
\$17 DAY | \$34 WK

KEROSENE



#791 HEATER 125 BTU
KEROSENE | RADIANT
\$57 DAY | \$172 WK



#97 HEATER
KEROSENE | 75K BTU
\$23 DAY | \$69 WK



#99 HEATER
KEROSENE | 175K BTU
\$42 DAY | \$125 WK



#100 HEATER
KEROSENE | 350K BTU
\$75 DAY | \$225 WK

IN-DIRECT



#784 INDIRECT HEATER
KEROSENE | 100,000 BTU
\$88 DAY | \$264 WK



#2092 INDIRECT HEATER
KEROSENE | 200,000 BTU
\$230 DAY | \$690 WK



#2091 HEATER INDIRECT
KEROSENE | 500K BTU
\$385 DAY | \$1,155 WK



#2093 INDIRECT HEATER
KEROSENE | 700,000 BTU
\$495 DAY | \$1,485 WK

PROPANE



#102 PROPANE HEATER
RADIANT | 200K BTU
\$18 DAY | \$36 WK



#101 HEATER
PROPANE | 80K BTU
\$46 DAY | \$138 WK



#103 HEATER
PROPANE | 170K BTU
\$92 DAY | \$276 WK



DUEL FUEL

#788 HEATER
PROPANE | 350K BTU
\$176 DAY | \$528 WK



914-592-2016 | 914-739-9000
OPEN MONDAY - SATURDAY 7 TO 5

**NO TRUCK? NO TIME?
NO PROBLEM! WE DELIVER!**



NEW!



#695 CHAIN SAW
BATTERY | 40 VOLT
\$40 DAY | \$160 WK



#205 CHAINSAW
16" | ELECTRIC
\$44 DAY | \$176 WK

Gas - 2 cycle



#179 CHAINSAW
16" | 2 CYCLE
\$55 DAY | \$220 WK

Gas - 2 cycle



#204 CHAINSAW
20" | 2 CYCLE
\$66 DAY | \$264 WK

#155 BRUSH CUTTER—10'
"HANDLE BAR"
\$50 DAY | \$200 WK



GAS - 2 CYCLE

#34 STRING TRIMMER
\$46 DAY | \$184 WK

EXTENDS 7" TO 11'

GAS - 2 CYCLE



#178 POWER POLE SAW
12" BLADE | TELESCOPIC
\$57 DAY | \$228 WK



#142 BACKPACK BLOWER
2 CYCLE | GAS
\$46 DAY | \$184 WK

#1401 STIHL COMBO
PLUS ATTACHMENTS AT
\$25/DAY
\$46 DAY | \$185 WK



#1402 KOMBI POWER BROOM
\$29 DAY | \$114 WK



#1403 KOMBI EXTENSION SHAFT
\$11 DAY | \$33 WK



#1404 KOMBI HEDGE TRIMMER
\$30 DAY | \$120 WK



#434 TREE DOLLY
1,500 LB CAPACITY
\$29 DAY | \$57 WK

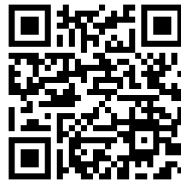

STIHL®
 DEALER WEBSITE QR CODE
 SEE ALL OF STIHL'S PRODUCTS

LAWN | GARDEN



#108 TRIMMER
 19" ELEC. DOUBLE EDGE
 \$23 DAY | \$69 WK



#107 TRIMMER
 30" 2 CYCLE | GAS
 \$50 DAY | \$200 WK



#144 PUSH BLOWER
 13 HP | GAS
 \$66 DAY | \$264 WK



#142 BACKPACK BLOWER
 2 CYCLE
 \$46 DAY | \$184 WK

WE STOCK AND SELL NEW **STIHL®** EQUIPMENT



CHAIN SAWS
 CUT-OFF SAWS
 BLOWERS
 TRIMMERS
 OIL & LUBRICANTS
 PARTS - SERVICE
 PRESSURE WASHERS
 SAFETY APPAREL



914-592-2016 | 914-739-9000
 OPEN MONDAY - SATURDAY 7 TO 5

NO TRUCK? NO TIME?
 NO PROBLEM! WE DELIVER!



#492 THATCHER
30" | PUSH | GAS | 9HP
\$92 DAY | \$368 WK



#493 THATCHER
22" | PUSH | GAS | 5 HP
\$69 DAY | \$276 WK



#192 THATCHER
18" | PUSH | GAS | 5HP
\$69 DAY | \$276 WK



#135 ROLLER
250LB | PUSH | POLY DRUM
\$13 DAY | \$26 WK



#180 OVERSEEDER
22" | PUSH | GAS
\$88 DAY | \$352 WK



#152 CORE AERATOR
18" | PUSH | GAS
\$69 DAY | \$276 WK



#153 CORE AERATOR
25" | SELF PROPELLED | GAS
\$92 DAY | \$368 WK



#683 CORE AERATOR
TOW BEHIND | 52"
\$66 DAY | \$264 WK



#134 LAWN MOWER
21" | PUSH W/BAG
\$40 DAY | \$120 WK



#154 LAWN MOWER
48" | COMMERCIAL WALK BEHIND
\$100 DAY | \$400 WK



#1425 RIDE ON LAWNMOWER
55" | HYDROSTATIC | GAS
\$220 DAY | \$880 WK



#680 FINISH MOWER
3-POINT HITCH
\$92 DAY | \$368 WK



#156 HIGH WEED FLAIL
BLADE MOWER | 32"
\$180 DAY | \$720 WK



#681 KUBOTA BRUSH CUTTER
48" | 3 PT HITCH
\$120 DAY | \$480 WK



#467 BOBCAT BRUSH HOG
60"
\$180 DAY | \$720 WK



#151 LAWN EDGER
10" | GAS
\$46 DAY | \$185 WK

CALL TODAY FOR
MONTHLY RATE!

NEW!

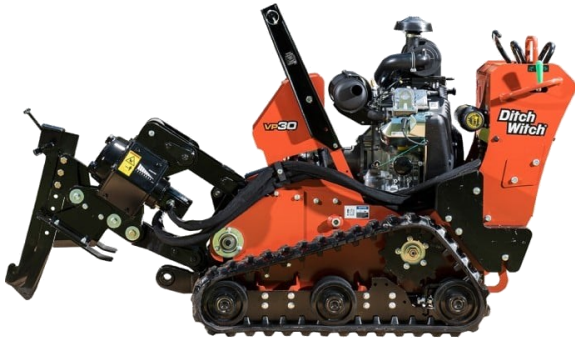

#494 PIPE PULLER
VIBRATORY PLOW | DIESEL
\$300 DAY | \$1,200 WK



#1420 BARRETO HYDRAULIC SOD CUTTER
18" | GAS | TRACK
\$150 DAY | \$525 WK



#230 ROTO-TILLER
MINI MANTIS
\$44 DAY | \$176 WK



#682 TILLER
3 PT HITCH | 58" WIDE
\$120 DAY | \$480 WK



#455 TRENCHER
5" X 26" | WALK BEHIND
\$176 DAY | \$704 WK



#231 ROTO-TILLER 24"
FRONT TINE - 5 HP
\$66 DAY | \$264 WK



#491 ROTO-TILLER
HYDRAULIC | FRONT TINE - 6 HP
\$92 DAY | \$368 WK



#232 ROTO-TILLER 20"
REAR TINE | HYDRAULIC
\$120 DAY | \$480 WK



914-592-2016 | 914-739-9000
OPEN MONDAY - SATURDAY 7 TO 5

NO TRUCK? NO TIME?
NO PROBLEM! WE DELIVER!



#495 STUMP GRINDER
 14" | SELF PROPELLED | 27 HP
 \$145 DAY | \$580 WK



#497 STUMP GRINDER
 20" | SELF PROPELLED | 31 HP
 \$330 DAY | \$1,320 WK



#0499 TRAILER FOR STUMP GRINDER
 4' X 6' UTILITY | 2,000 LB CAPACITY | TILTING
 \$80 DAY | \$320 WK



#1561 BATTERY OPERATED CHAINSAW KIT
 20" | BATTERY KIT
 2 BATTERIES & CHARGER
 \$80 DAY | \$320 WK

#1560 BATTERY OPERATED CHAINSAW KIT
 16" | BATTERY KIT
 2 BATTERIES & CHARGER
 \$75 DAY | \$300 WK



#205 CHAIN SAW
 16" | 2 CYCLE | ELECTRIC
 \$44 DAY | \$176 WK



#204 CHAIN SAW
 18" | 2 CYCLE | GAS
 \$66 DAY | \$264 WK



#0179 CHAIN SAW
 16" | 2 CYCLE | GAS
 \$55 DAY | \$220 WK

**WE SELL CHAINS, BINDERS, SHARPEN TOOLS & SO MUCH MORE!
 COME VISIT OUR SHOWROOM IN ELMSFORD OR PEEKSKILL!**



#1030 TREE CHIPPER
 18" | 173 HP | DIESEL
 \$770 DAY | \$3,080 WK



#145 LOG SPLITTER
 VERTICAL | 20 TON GAS
 \$90 DAY | \$360 WK



#250 TREE CHIPPER
 12" | 80 HP | DIESEL
 \$375 DAY | \$1,500 WK



#249 TREE CHIPPER
 4" | GAS | AUTO FEED
 \$250 DAY | \$875 WK



**CALL TODAY FOR
 MONTHLY RATES!**



914-592-2016 | 914-739-9000
 OPEN MONDAY - SATURDAY 7 TO 5

**NO TRUCK? NO TIME?
 NO PROBLEM! WE DELIVER!**



Optional Auger Bits Available 6" - 36"

Rented Separately

CALL TODAY FOR MONTHLY RATE!



#461 AUGER ATTACHMENT
BOBCAT | 6" TO 36" AVAIL
\$92 DAY | \$368WK



#486 AUGER ATTACHMENT
MIN-SKID | 4" TO 36" AVAIL
\$75 DAY | \$300 WK

#575 SCREENING PLANT
PORTABLE | 110V | 12 AMP
\$250 DAY | \$1,000 WK

GENERATOR REQUIRED—3,000 WATT MIN.



#176 POST HOLE DIGGER
1 MAN | HYDRAULIC 3" - 14"
\$92 DAY | \$370 WK



#765 UNDER SIDEWALK ATTACHMENT
FOR POST HOLE DIGGER 3" X 10'
\$33 DAY | \$132 WK



#397 DUMP TRAILER
2 YD | 7,500# CAP
\$145 DAY | \$580 WK



#398 UTILITY TRAILER
4' X 6' | 500 # CAP. |
\$40 DAY | \$120 WK



#424 CONVEYOR BELT
20' W/ HOPPER | ELEC.
\$150 DAY | \$600 WK

20' OR 24'!



#425 CONVEYOR BELT
24' W/ HOPPER | ELEC.
\$175 DAY | \$700 WK

CALL TODAY FOR MONTHLY RATE!

UTVS



#8951 UTILITY CARRY ALL 1500—2 PASSENGER

\$242 DAY | \$495 WK

**POWERTRAIN KAWASAKI 20.1
HP-RATED GASOLINE ENGINE
CAPACITY 1,200 LB
BED LOAD CAPACITY STANDARD 800 LB (363 KG);
HIGH CAPACITY OPTION 1,050 LB (476 KG)
TOP SPEED 25 MPH**



#8952 UTILITY CARRY ALL 1700—4 PASSENGER

\$275 DAY | \$550 WK

**FOUR-PASSENGER WITH INTELLITRAK™
AUTOMATIC ALL-WHEEL DRIVE
POWERTRAIN KUBOTA 20 HP-RATED (15.0 KW)
DIESEL ENGINE
TOTAL VEHICLE CAPACITY 1,600 LB (726 KG)
BED LOAD CAPACITY 800 LB (363 KG)
TOP SPEED 25 MPH
ADDS TWO ADDITIONAL FORWARD FACING SEATS,
WITHOUT CUTTING CARGO SPACE.**

#1020 GROUND HEATER

\$1,100 DAY | \$3,850 WK



**GROUND THAWING CAPACITY 5,600 FT²
CONCRETE CURING CAPACITY 11,200 FT²
TEMPORARY HEATING CAPACITY 12,000 FT²
HEATER CAPACITY 273,000 BTU HEATING FUEL INPUT
FIELD HOSES 4 - 700 FT
MANIFOLDS (SUPPLY & RETURN) 4 - 5/8" & 1 - 1 1/4"
QUICK CONNECT
ELECTRICAL REQUIREMENTS 2 - 120V AC 20A CIRCUIT
UNIT HAS 7KW DIESEL GENERATOR
GLYCOL TANK CAPACITY 96 US GAL
FUEL TANK CAPACITY 192 US GAL
RUN TIME UP TO 120 HOURS
WEIGHT (FUEL TANK FULL/EMPTY) 4,700 / 6,080#
LENGTH (FROM HITCH) 12' WIDTH 80" HEIGHT 80"
ON BOARD DIESEL GENERATOR 7KW**

GROUND HEATER



**914-592-2016 | 914-739-9000
OPEN MONDAY - SATURDAY 7 TO 5**

**NO TRUCK? NO TIME?
NO PROBLEM! WE DELIVER!**

CALL TODAY FOR MONTHLY RATE!

Generators Sold & Serviced

Generator Rates are for Single Shift use.

**LED LIGHTS
4,000
WATTS
OF LIGHT**



#426 LIGHT TOWER
4 KW WATT GENERATOR
\$176 DAY | \$440 WK



#82 GENERATOR
10.5 KW | DIESEL
\$154 DAY | \$616 WK



#86 GENERATOR
3,000 WATT | GAS
\$60 DAY | \$240 WK



#87 GENERATOR
5-6,000K | GAS
\$90 DAY | \$360 WK



#84 GENERATOR
2,000 WATT | GAS | SUPER QUIET
\$40 DAY | \$160 WK



#954 GENERATOR
3,000 WATT | GAS | SUPER QUIET
\$75 DAY | \$300 WK



#2004 GENERATOR
6,500 WATT | GAS | SUPER QUIET
\$140 DAY | \$560 WK



#590 GENERATOR
8,000 WATT | GAS
\$115 DAY | \$460 WK

Shift Rates May Apply

GENERATORS



#83 GENERATOR
 25KW | 3 PHASE | DIESEL
 60 AMP MAIN BREAKER
\$225 DAY | \$845 WK

WTR # 83	MP 25
Kw/Kva	20 kw / 25
Fuel Cap	51.5 gal
Run Time @ 100%	31 hours
Decibels 23'	63 dba
Single Phase 120v	60 x2 amps
Single Phase 240v	60 amps
Three Phase 208v	65 amps
Three Phase 240v	60 amps
Three Phase 480v	30 amps



#2121 GENERATOR
 45KW | 3 PHASE | DIESEL
 800 AMP MAIN BREAKER
\$325 DAY | \$1,150WK

WTR # 2121	SDG45S-8E2
Kw/Kva	38.8 / 48.5
Fuel Cap	80.5
Run Time@100%	28.75 hours
Decibels 23'	57 dba
Single Phase 120v	108 x 2 amps
Single Phase 240v	108
Three Phase 240v	108
Three Phase 480v	54



#89 GENERATOR
 65KW | 3 PHASE | DIESEL
 175 AMP MAIN BREAKER
\$375 DAY | \$1,350 WK

WTR # 89	MMD 65
Kw/Kva	63 kw/50
Fuel Cap	106 gal
Run Time@100%	27 hours
Decibels @ 23'	65 dba
Single Phase 120v	152 x 2 amps
Single Phase 240v	152 amps
Three Phase 208v	167 amps
Three Phase 240v	152 amps
Three Phase 480v	76 amps



#88 GENERATOR
 125KW | 3 PHASE | DIESEL
 300 AMP MAIN BREAKER
\$505 DAY | \$1,515 WK

WTR # 88	MQ DCA125
Kw/Kva	100 kw / 125
Fuel Cap	169 gal
Run Time @ 100%	23 hours
Decibels 23'	65 dba
Single Phase 120v	300 x 2 amps
Single Phase 240v	300 amps
Three Phase 208v	338 amps
Three Phase 240v	300 amps
Three Phase 480v	150 amps



#2005 TRANS CUBE
 125 GALLON CAPACITY
\$110 DAY | \$275 WK



#2008 TRANS CUBE
 260 GALLON CAPACITY
\$138 DAY | \$276 WK

- * **DOUBLE WALLED**
- * **110% FUEL CONTAINMENT**
- * **110 VOLT TRANSFER PUMP**



#2125 GENERATOR
 150KW | 3 PHASE | DIESEL
 400 AMP MAIN BREAKER
\$600 DAY | \$2,100 WK

WTR # 2125	MMD 150
Kw/Kva	120 kw /150
Fuel Cap	215 gal
Run Time @ 100%	25 hour
Decibels 23'	68 dba
Single Phase 120v	363 X 2 amps
Single Phase 240v	363 amps
Three Phase 208v	394 amps
Three Phase 240v	361 amps
Three Phase 480v	180 amps



914-592-2016 | 914-739-9000
 OPEN MONDAY - SATURDAY 7 TO 5

**NO TRUCK? NO TIME?
 NO PROBLEM! WE DELIVER!**



EXTENSION CORD 12/3
10', 25', 50', 100'
\$7 TO \$20



#2041 1 PHASE CORD
6/4 - 25 AMP | 1 PHASE
\$29 DAY | \$58 WK



#2015 DISTRO BOX PASS THROUGH
100 AMP | 3 PHASE
\$150 DAY | \$225 WK



#2013 DEAD END DISTRO BOX
100 AMP | 3 PHASE
\$150 DAY | \$225 WK



#2043 50' EXTENSION CORD
6/4 - 50 AMP | 3 PHASE
\$46 DAY | \$92 WK



#2042 25' EXTENSION CORD
6/4 - 50 AMP | 3 PHASE
\$29 DAY | \$58 WK



#2048 DISTRO BOX
220V | 1 PHASE
\$85 DAY | \$110 WK



#2031 DISTRO BOX PASS
3-50 AMP | 3 PHASE
\$150 DAY | \$225 WK



#2006 CABLE RAMP 36"
CABLE COVERS
\$25 DAY | \$50 WK



#2022 PIGTAIL KIT
"WHIPS" FOR TIE-INS
100 AMP | 3 PHASE
\$30 DAY | \$30 WK

Cam Lock Cables



	SET 5PC	DAY	WK
#2019	10'-2/0	\$23	\$46
#2020	25'-2/0	\$35	\$70
#2017	50'-2/0	\$57	\$114
#2036	100'-2/0	\$114	\$228



#2053 SIAMESE SPLITTER
\$11 DAY | \$22 WK (EACH)



#2050 CAM LOCK "T"
5 PIECE KIT
\$22 DAY | \$44 WK



#2052 CAM GENDER CHANGER
M-M | FM-FM—EACH
\$6 DAY | \$12 WK



#2010 TRANSFORMER
75KVA | 480V-208V | 3 PHASE
\$250 DAY | \$625 WK



#820 SOIL AIR PICK
\$28 DAY | \$84 WK



#14 AIR COMPRESSOR
185 CFM DIESEL
\$160 DAY | \$480 WK



#12 AIR COMPRESSOR
400 CFM DIESEL
2" HOSE OR 3/4" HOSE
\$320 DAY | \$1,280 WK



#700 AIR HOSE 50'
\$15 DAY | \$30 WK

CALL TODAY FOR MONTHLY RATE!



#19 CHIPPING HAMMER
18 # | AIR
\$35 DAY | \$140 WK



#6 HYDRAULIC ROCK SPLITTER KIT
1-3/4 X 26" HOLE REQUIRED
POWERPACK BY ITSELF & SPLITTER FROM BROCK
\$350 DAY | \$1,400 WK



#17 ROCK DRILL
55 # | 1" STEEL
\$64 DAY | \$256 WK



#18 PAVEMENT BREAKER
30 # | 1" STEEL
\$42 DAY | \$168 WK



#16 PAVEMENT BREAKER
60 # | 1-1/8" STEEL
\$44 DAY | \$176 WK



#15 PAVEMENT BREAKER
90 # | 1-1/8" STEEL
\$44 DAY | \$176 WK

We Rent & Sell
Points
Chisels
Rock Bits



#196 SANDBLASTER
100 LB POT W/REMOTE
\$72 DAY | \$288 WK



#197 SANDBLASTER
300 # POT W/REMOTE
\$116 DAY | \$464 WK



914-592-2016 | 914-739-9000
OPEN MONDAY - SATURDAY 7 TO 5

**NO TRUCK? NO TIME?
NO PROBLEM! WE DELIVER!**

CALL TODAY FOR MONTHLY RATE!



#456 TRACTOR LOADER / BACKHOE

\$285 DAY | \$1,140 WK



HORSE POWER	26 HP
WIDTH	5'4"
LENGTH	11'1"
WEIGHT	6,480 #
MAX DUMP HEIGHT	9'9"
BUCKET WIDTH	72"
LOAD RATING	1,850 #
DIGGING DEPTH	7 FT

3 POINT HITCH W/ PTO

COMPACT



#680 FINISH MOWER 60"

\$92 DAY | \$368 WK



#681 BRUSH CUTTER

\$120 DAY | \$480 WK



#682 ROTOTILLER 58"

\$120 DAY | \$480 WK



**#683 CORE AERATOR—
TOW BEHIND**

**52"
\$66 DAY | \$264 WK**

No Truck? No Time? No Problem! WE DELIVER!

HORSE POWER 45 HP
 WEIGHT 7,173 #
 WIDTH 72.5"
 LENGTH 19'7"
 BACKHOE DIGGING DEPTH 10'1"
 BACKHOE MAX DUMP HEIGHT 7'6"
 BACKHOE BUCKET WIDTH 18"
 LOADER DUMP HEIGHT 9'5"
 BUCKET WIDTH 72"

#460 KUBOTA TRACTOR LOADER BACKHOE

HYDROSTATIC | ALL WHEEL DRIVE
 72" BUCKET | 10' DIG DEPTH
\$350 DAY | \$1,400 WK

3 POINT HITCH W/ PTO



#481 MINI SKID STEER

TRACKED | ATTACHMENTS AVAILABLE
\$220 DAY | \$880 WK



#486 AUGER ATTACHMENT
 36" CAPACITY | 6" TO 36" AVAIL
\$75 DAY | \$300 WK



#484 SOIL CONDITIONER 48"
 MINI SKID STEER ATTACHMENT
\$125 DAY | \$500 WK



#485 MINI SKID BROOM
 48" WIDE
\$95 DAY | \$475 WK



914-592-2016 | 914-739-9000
 OPEN MONDAY - SATURDAY 7 TO 5

**NO TRUCK? NO TIME?
 NO PROBLEM! WE DELIVER!**



#454 HYDRAULIC HAMMER
500 # CLASS
\$230 DAY | \$920 WK



#450T TOOTH BUCKET



#450S SMOOTH BUCKET

INCLUDES 1 BUCKET WITH BOBCAT RENTAL

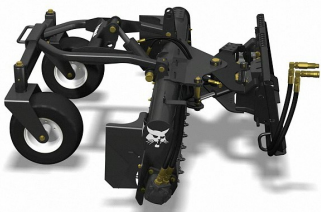

#469 SOIL CONDITIONER 72"
\$176 DAY | \$704 WK



#488 LANDSCAPE RAKE 72"
\$140 DAY | \$560 WK



#446 YORK RAKE 72"
3 POINT HITCH
\$72 DAY | \$286 WK



#467 BRUSH HOG 60"
\$180 DAY | \$720 WK



#465 14" STANDARD FLOW PLANER
INCLUDES WATER TANK
\$350 DAY | \$1,400 WK



#457 SOLID TIRE SET (4)
\$72 DAY | \$216 WK



#461 POST HOLE
\$92 DAY | \$368 WK



#466 AUGER
6" - 9" - 12" - 18"
\$24 DAY | \$72 WK



#459 SWEEPER W/HOPPER 72"
\$195 DAY | \$780 WK



#489 ANGLE BROOM 68"
\$180 DAY | \$720 WK



#458 FORKS
\$40 DAY | \$160 WK



#447 GRAPPLE BUCKET
\$92 DAY | \$368 WK

#450 SKID STEER LOADER
 RUBBER TIRE | S175/S570
 \$275 DAY | \$1,100 WK



HORSE POWER	61 HP
WIDTH	67"
LENGTH	11'1"
WEIGHT	6,480 #
MAX DUMP HEIGHT	7'6"
BUCKET WIDTH	68"
LOAD RATING	1,950 #
AUX HYDRAULICS	17.1 GPM

#473 TRACK LOADER
 RUBBER TRACK | T590
 \$400 DAY | \$1,400 WK



IMAGES SHOWN ARE FOR REFERENCE ONLY. ACTUAL MODELS AND INVENTORY MAY VARY.

HORSE POWER	66 HP
WIDTH	67"
LENGTH	11'1"
WEIGHT	7,822 #
MAX DUMP HEIGHT	91.3"
BUCKET WIDTH	68"
LOAD RATING	2,100 #
AUX HYDRAULICS	17.1 GPM

#474 TRACK LOADER
 RUBBER TRACK | T650
 \$495 DAY | \$1,980 WK



HORSE POWER	74 HP
WIDTH	73"
LENGTH	12'25"
WEIGHT	10,250 #
MAX DUMP HEIGHT	8'3"
BUCKET WIDTH	80"
LOAD RATING	2,900
AUX HYDRAULICS	30.5 GPM

#740 JCB WHEEL LOADER

1 YARD | CAB | DIESEL | 64 HP ENGINE
 \$300 DAY | \$1050 WK



HORSE POWER	64 HP
WEIGHT	9,396 #
WIDTH	5'11"
LENGTH	11'9"
HEIGHT (CAB)	7'4"
BACKHOE DIGGING DEPTH	8'4"
BACKHOE MAX DUMP HEIGHT	10'1"
BACKHOE BUCKET WIDTH	9" TO 24"
LOADER BUCKET	7'3"
DUMP HEIGHT	7'3"

CAB DOORS AVAILABLE FOR MOST MODELS—VARIOUS MODELS IN RENTAL FLEET



914-592-2016 | 914-739-9000
 OPEN MONDAY - SATURDAY 7 TO 5

**NO TRUCK? NO TIME?
 NO PROBLEM! WE DELIVER!**



**RUNS 8 HOURS ON 1 CHARGE.
"0" EMISSION**

**#875 BATTERY POWERED EXCAVATOR
2,060 #**

**9VXB | REACH 5'-2" | 12" BUCKET | RUBBER TRACKS
\$385 DAY | \$1,540 WK**



**#2600 TRENCH BOX
6'L X 40"-60"W X 6'H
MODULAR 2 SIDED ALUMINUM
\$200 DAY | \$500 WK**



**NO TRUCK? NO TIME? NO PROBLEM!
WE DELIVER TO YOUR DOOR OR JOB!**

**CALL TODAY FOR
MONTHLY RATE!**



**#454 HYDRAULIC HAMMER
500 # CLASS
\$230 DAY | \$920 WK**



**#453 HYDRAULIC HAMMER
750 # CLASS
\$325 DAY | \$1298 WK**



**#475 HYDRAULIC HAMMER
1,000 # CLASS
\$440 DAY | \$1,760 WK**

CALL TODAY FOR MONTHLY RATE!

	WTR # 451	WTR # 452	WTR # 470	WTR # 477
Class	35	55	85	140
Max Digging Depth	10'11"	12'8"	14'2"	18'2"
Max Digging Height	17'	18'10"	22'8"	29'8"
Max Dumping Height	12'	12'10"	16'1"	21'11"
Horse Power	23 HP	63-8 HP	57 HP	105 HP
Weight:	8,082 #	12,733 #	18,775 #	35,000 #
Width	5'1"	6'6"	7'3"	8'2"
Length	15'7"	19'3"	19'10"	24'6"
Height	8'1"	8'5"	8'7"	9'3"
Bucket Width	18/24"	24"	30"	30"
Hydraulic Thumb	✓	✓	✓	✓
Back Fill Blade	✓	✓	✓	✓
A-F Pattern Valve	✓	✓	✓	✓
Rubber Track	✓	✓	✓	✓

**DIFFERENT BUCKETS AVAILABLE*



RUBBER PADS

#477 EXCAVATOR

35,000 # | KATO HD 514
98'-2/ REACH | 30" BUCKET
\$750 DAY | \$2,625WK



RUBBER TRACKS

#451 MINI EXCAVATOR

8,000 # | 35V5
8'-6" REACH | 18" BUCKET
\$350 DAY | \$1,400 WK



RUBBER TRACKS

#452 MINI EXCAVATOR

12,000 # | 55V4
12' REACH | 24" BUCKET
\$465 DAY | \$1,860 WK



RUBBER TRACKS

#470 MINI EXCAVATOR

19,000 # | 80NX
15' REACH | 30" BUCKET
\$625 DAY | \$2,500 WK



914-592-2016 | 914-739-9000
OPEN MONDAY - SATURDAY 7 TO 5

NO TRUCK? NO TIME?
NO PROBLEM! WE DELIVER!



#1025 FORD F550 DUMP TRUCK

\$440 DAY | \$1,320 WK
 50 MILES INCLUDED— \$.40/MILE

FORD F550 DUMP TRUCK

19,000 GVW
 3-4 YARD
 GAS ENGINE
 4 WD
 AUTOMATIC

INCLUDES TARP & ASPHALT CHUTE
INSURANCE RIDER RECOMMENDED

#397 DUMP TRAILER

2 YARD—7,500 CAP
 ELECTRIC BRAKES
\$145 DAY | \$580 WK



TRAILER ACCESSORIES

- CHAINS
- BINDERS
- NYLON STRAPS
- PINTLE HOOK

**AVAILABLE FOR
 RENT OR SALE**



#401 EQUIPMENT TRAILER

9,900 # CAP | 8' X 16' | SURGE BRAKES
\$100 DAY | \$400 WK



#406 3 TON ROLLER TRAILER

9,900 # CAP | 5' X 10' | ELECTRIC BRAKES
\$100 DAY | \$400 WK



#399 EQUIPMENT TRAILER

9 TON | W/RAMPS | ELECTRIC BRAKES
\$160 DAY | \$640 WK



#400 EQUIPMENT TRAILER

3,000 # CAP | 6' 5"X12' | SURGE BRAKES
\$80 DAY | \$320 WK

#595 PLATE COMPACTOR

20" REVERSIBLE

\$116 DAY | \$464 WK



SPEEDS OF UP TO 5,500 VIBRATIONS PER MINUTE AND 350 SQUARE METERS PER HOUR!



MOST POPULAR

#228 PLATE COMPACTOR

20" TAMPER W/WATER TANK

\$90 DAY | \$360 WK

USE ON PAVERS



#309 JUMPING JACK

11" | 4 CYCLE RAMMER

\$92 DAY | \$370 WK



#865 PLATE COMPACTOR

17" | BATTERY OPERATED

\$110 DAY | \$440 WK



#227 PLATE COMPACTOR

12" | GAS

\$69 DAY | \$276 WK



#228P 20" PAVER

POLYURETHANE PAD

\$21 DAY | \$84 WK

CALL TODAY FOR MONTHLY RATE!



#188 TRENCH ROLLER

SHEEP'S FOOT W/ REMOTE

\$396 DAY | \$1,386 WK



#187 DOUBLE ROLLER

26" VIBRATING

\$185 DAY | \$740 WK



#189 VIBRATORY ROLLER

3 TON | ARTICULATED

\$325 DAY | \$1,300 WK



#190 ASPHALT TORCH

*PROPANE NOT INCLUDED

\$13 DAY | \$26 WK



#225 ASPHALT HAND ROLLER

\$23 DAY | \$69 WK



#191 VIBRATORY ROLLER

1-1/2 TON | ARTICULATED

\$225 DAY | \$900 WK



914-592-2016 | 914-739-9000
OPEN MONDAY - SATURDAY 7 TO 5

NO TRUCK? NO TIME?
NO PROBLEM! WE DELIVER!

SCISSOR



WTR #240 LGMG S1932E

\$150 DAY | \$330 WK

WORKING HEIGHT	25'
PLATFORM HEIGHT	19'
LENGTH / WIDTH	70"/30"
HEIGHT STOWED	78.5"
HEIGHT RAILS COLLAPSED	65"
WEIGHT	2,580 #
DECK EXTENSION	3'
MAX CAPACITY	500 #



WTR #238 LGMG S3246E

\$150 DAY | \$375 WK

WORKING HEIGHT	32'
PLATFORM HEIGHT	26'
LENGTH/WIDTH	91"/46"
HEIGHT STOWED	84.5"
HEIGHT RAILS COLLAPSED	70.5"
WEIGHT	4700 #
DECK EXTENSION	4'
MAX CAPACITY	700 #

CALL TODAY FOR MONTHLY RATE!

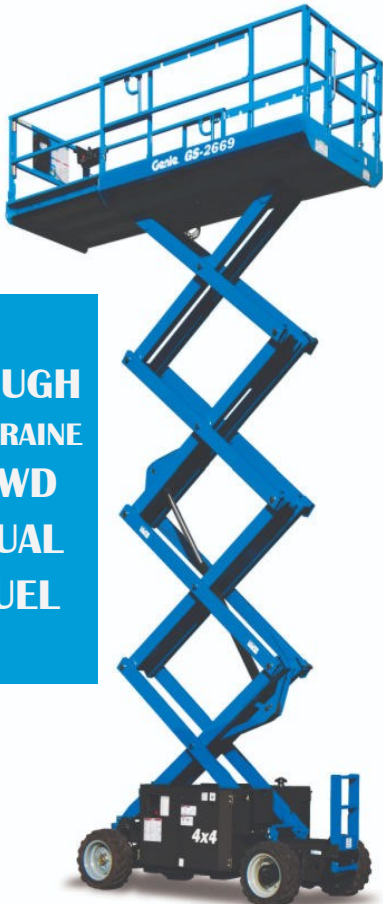

WTR #239 GENIE 3369 RT

\$300 DAY | \$900 WK

WORKING HEIGHT	38'8"
PLATFORM HEIGHT	32'8"
LENGTH/WIDTH	12'4"/5'9"
HEIGHT STOWED	8'6"
HEIGHT RAILS COLLAPSED	6'3.5"
WEIGHT	8,449 #
DECK EXTENSION	5'
MAX CAPACITY	1000 #



WTR #241 GENIE GS2632

\$150 DAY | \$375 WK

WORKING HEIGHT	32'
PLATFORM HEIGHT	26'1"
LENGTH / WIDTH	8'/2'8"
HEIGHT STOWED	7'6"
HEIGHT RAILS COLLAPSED	6'4"
WEIGHT	4,413 #
DECK EXTENSION	3'
MAX CAPACITY	500 #

ROUGH TERRAINE 4WD DUAL FUEL



WTR # 245 NIFTY TM34TG

\$230 DAY | \$920 WK

WORKING HEIGHT	40'5"
PLATFORM HEIGHT	34"
HORIZONTAL REACH	16'6"
WEIGHT	3,400 #
LENGTH	18'10"
WIDTH RIGGERS UP	3'7"
WIDTH RIGGERS DN	8'10"
MAX CAPACITY	500 #



WTR # 248 NIFTY TM50TG

\$330 DAY | \$1,320 WK

WORKING HEIGHT	56'
PLATFORM HEIGHT	49'6"
HORIZONTAL REACH	28'6"
WEIGHT	4,890 #
LENGTH	20'4"
WIDTH RIGGERS UP	5'5"
WIDTH RIGGERS DN	14'5"
MAX CAPACITY	500 #

**TRAINING CLASSES
AVAILABLE**



WTR# 242 JLG 25 AM DC

\$120 DAY | \$300 WK

WORKING HEIGHT	31'
PLATFORM HEIGHT	25'2"
HEIGHT STOWED	6'6"
WEIGHT	766 #
LENGTH STOWED	4'1"
WIDTH STOWED	2'5"
OUT RIGGER LENGTH	5'2"
OUT RIGGER WIDTH	4'5"
MAX CAPACITY	350 #



**No Truck? No Time?
No Problem!**

**We Deliver to Your
Door or Job!**

**Open Monday to
Friday 7am-5pm**

**Open Saturday
7am-3pm**

**914-592-2016
Elmsford**

**914-739-9000
Peekskill**



WTR# 1070 GENIE AWP-30S

\$250 DAY | \$625 WK

WORKING HEIGHT	35' 6"
PLATFORM HEIGHT	29' 6"
HEIGHT STOWED	6' 6"
WEIGHT	867 #
LENGTH STOWED	4' 7"
WIDTH STOWED	2' 5"
OUT RIGGER LENGTH	4' 7"
OUT RIGGER WIDTH	2' 5"
MAX CAPACITY	350 #



**914-592-2016 | 914-739-9000
OPEN MONDAY - SATURDAY 7 TO 5**

**NO TRUCK? NO TIME?
NO PROBLEM! WE DELIVER!**

CALL TODAY FOR MONTHLY RATE!

85'

#1080 ELECTRIC TELESCOPIC BOOM LIFT

85' | DUEL FUEL | 4 WD
\$1,195 DAY | \$3,000 WK



GENIE S85	WTR #1080
MAX PLATFORM HEIGHT	84.98 FT IN
MAX HORIZONTAL REACH	76.45 FT IN
PLATFORM INNER WIDTH	96.07 IN
MAX PLATFORM WEIGHT CAPACITY	500.45 LB
PLATFORM INNER LENGTH	35.83 IN
MAX WORKING HEIGHT	90.88 FT IN
PLATFORM ROTATION	160 DEGREES
HORIZONTAL REACH	74' 6" 22.71M
BELOW GROUND REACH	8' 8" 2.64M
PLATFORM CAPACITY	660 LB UNRESTRICTED, 1,000 LB RESTRICTED 300 KG UNRESTRICTED, 454 KG RESTRICTED
MACHINE WIDTH AND LENGTH	8' 2", 41' 9" 2.49M, 12.37M



#1078 BOOM LIFT - TELESCOPIC

65' | DIESEL | 4WD | 660# CAP.
\$460 DAY | \$1,380 WK



LGMG	WTR #1078
MAX PLATFORM HEIGHT	65'
MAX HORIZONTAL REACH	54'-6"
PLATFORM INNER WIDTH	2'-11"
MAX PLATFORM WEIGHT CAPACITY	660 #
PLATFORM INNER LENGTH	8'
MAX WORKING HEIGHT	71'
PLATFORM ROTATION	90"
HORIZONTAL REACH	54'-6"
BELOW GROUND REACH	10'
MACHINE WIDTH AND LENGTH	8'-2", 33'-6"

65'



#244 BOOM LIFT - ARTICULATED

65' | DUEL FUEL | 4 WD
\$600 DAY | \$1,725 WK

GENIE Z-62/40	WTR #244
WORKING HEIGHT	67'11"
PLATFORM HEIGHT	62'
HORIZONTAL REACH	40-9"
WEIGHT	22,690 #
LENGTH	30'3"
WIDTH	8'6"
MAX CAPACITY	500 #



BOOM LIFTS



62'



Genie Z45	WTR # 243
Working Height	51'-6"
Platform Height	45'-6"
Horizontal Reach	24'9"
Weight	16,360 #
Length	21'-10"
Width	7'6"
Max Capacity	500 #



42'

NIFTY SD50	WTR # 247
WORKING HEIGHT	56'
PLATFORM HEIGHT	49'
HORIZONTAL REACH	28' 6"
WEIGHT	5950 #
LENGTH	18' 4"
WIDTH OUT RIGGERS UP	14' 5"
WIDTH OUT RIGGERS DOWN	5' 3"
MAX CAPACITY	500 #



45'



#247 BOOM LIFT - ARTICULATED

50' | DIESEL | 4WD
\$460 DAY | \$1,380 WK



#243 BOOM LIFT - ARTICULATED

45' | DUEL FUEL | 4 WD
\$475 DAY | \$1,425 WK



914-592-2016 | 914-739-9000
OPEN MONDAY - SATURDAY 7 TO 5

NO TRUCK? NO TIME?
NO PROBLEM! WE DELIVER!

TELEHANDLER

#442 TELEHANDLER 32'
12,000 # | DIESEL
\$396 DAY | \$1,320 WK

#732 TELEHANDLER 44'
8,000 # | 4 WD
\$600 DAY | \$1,750 WK

#730 TELEHANDLER 19'
5,000 # | DIESEL
\$286 DAY | \$858 WK

12,000 lb



8,000 lb



5,000 lb



WTR #442		WTR #732 GENIE GTH 844		WTR #730 GENIE 5519	
CAPACITY	12,000 #	CAPACITY	8,000 #	CAPACITY	5,511 #
MAX LIFT HEIGHT	56'	MAX LIFT HEIGHT	44'	MAX LIFT HEIGHT	18.8'
MAX HORIZONTAL REACH	42'	MAX HORIZONTAL REACH	27'	MAX HORIZONTAL REACH	11.3'
STOWED HEIGHT	8'-18"	STOWED HEIGHT	8'9"	STOWED HEIGHT	6.5'
STOWED LENGTH	21'-7"	STOWED LENGTH	20'	STOWED LENGTH	12.2'
WIDTH	7'-11"	WIDTH	8'5"	WIDTH	5.9'
WEIGHT	34,833 #	WEIGHT	22,500 #	WEIGHT	10,000 #

Solutions That Fit Your Schedule

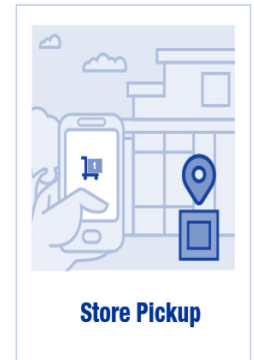
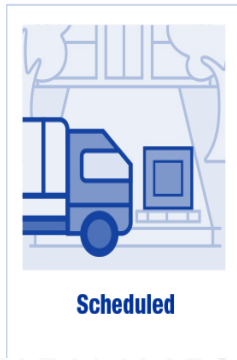
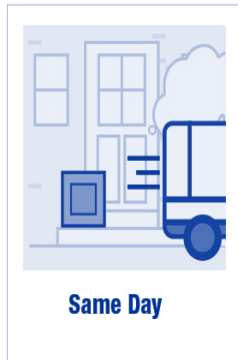

11 VREELAND AVE ELMSFORD 914-592-2016
1075 WASHINGTON ST PEEKSKILL 914-739-9000



Forklift and Boom Certification Classes Available

FORKLIFT

#443 FORK LIFT 6,000#

6,000 # | 15' MAX HEIGHT | 42" FORKS
\$280 DAY | \$910 WK

#738 FORK LIFT 6,000

6,000 # | 15' MAX HEIGHT | 42" FORKS
CAB UNIT
\$525 DAY | \$1575 WK

#0736 FORKLIFT CAB 7,000

16' | DUEL FUEL | CAB
\$350 DAY | \$1050 WK



6,000 lb



6,000 lb



7,000 lb



WTR # 443	
Power	Gasoline / LPG
Capacity @ 24"	6,000 #
Fork Length	48"
Max Mast Height	176"
Max Fork Height	128"
Weight	9,405 #
Length w/ Forks	148.8"
Width	48.6"
Stowed Height	85"

WTR # 738	
Power	Gasoline / LPG
Capacity @ 24"	6,000 #
Fork Length	48"
Max Mast Height	240"
Max Fork Height	189"
Weight	11,000 #
Length w/ Forks	160"
Width	48.6 "
Stowed Height	87"

WTR # 0736	
Power	Gasoline / LPG
Capacity @ 24"	7,000 #
Fork Length	48"
Max Mast Height	10' 120"
Max Fork Height	10' 120"
Weight	11,000 #
Length w/ Forks	170"
Width	48"
Stowed Height	89"



#728 CARPET POLE
10'X 2 1/2"
\$45 DAY | \$135 WK

WTR # 735	
Power	Gasoline/LPG
Capacity @ 24"	10,000 #
Fork Length	60"
Max Mast Height	171.8"
Max Fork Height	118.1"
Weight	15,928 #
Length w/ Forks	185.4"
Width	72"
Stowed Height	101.8"



10,000 lb



#0445 FORK EXTENSIONS
\$23 DAY | \$46 WK

#735 FORK LIFT 10,000#
10,000 # | DUEL FUEL
\$396 DAY | \$1,386 WK



914-592-2016 | 914-739-9000
OPEN MONDAY - SATURDAY 7 TO 5

NO TRUCK? NO TIME?
NO PROBLEM! WE DELIVER!



8' OR 15' BEAM

#562 GANTRY
 3/4 TON CAP
 \$116 DAY | \$348 WK

#560 GANTRY
 2 TON CAP
 \$116 DAY | \$348 WK



#365 CHAIN HOIST
 3 TON | 20' CHAIN \$57
 \$57 DAY | \$228 WK



#367 CHAIN HOIST
 1 TON | 20' | **ELECTRIC**
 \$150 DAY | \$600 WK



#30 JOHNSON BAR
 FOR LEVERAGE
 \$23 DAY | \$46 WK

**CALL TODAY
 FOR
 MONTHLY
 RATE!**



**1,500 #
 CAPACITY**



#435 STAIR CLIMBING
 HAND TRUCK | **BATTERY**
 \$90 DAY | \$360 WK



**#29 APPLIANCE
 HAND TRUCK**
 \$18 DAY | \$54 WK



#31 HAND TRUCK
 \$18 DAY | \$36 WK



#433 WAREHOUSE DOLLY
 30" X 60" | 1,500 CAP
 \$35 DAY | \$105 WK



#33 MOVERS DOLLY
 \$11 DAY | \$22 WK



#432 CONTRACTOR LIFT
12 FT. 400 # CAP
\$75 DAY | \$225 WK



#558 COUNTER BALANCE LIFT
15' LIFT | 800 # CAPACITY
\$143 DAY | \$429 WK



#430 MATERIAL LIFT
18 FT. | 650 # CAP
\$100 DAY | \$300 WK



#429 ROUST-A-BOUT
25' LIFT | 1,500 LB. CAP.
\$116 DAY | \$348 WK



#122 PALLET JACK
6,000 # CAPACITY
\$35 DAY | \$140 WK



#726 ELECTRIC PALLET JACK
4,500 # CAPACITY
\$165 DAY | \$650 WK

#679 SOLAR PANEL ATTACHMENT
ALSO PLYWOOD, PANELING
\$23 DAY | \$69 WK



#670 PLATFORM HOIST
16' TO 44' | 400 #
\$125 DAY | \$500 WK

**WE CARRY
CHAINS
BINDERS
SLINGS**



914-592-2016 | 914-739-9000
OPEN MONDAY - SATURDAY 7 TO 5

**NO TRUCK? NO TIME?
NO PROBLEM! WE DELIVER!**

CALL TODAY FOR MONTHLY RATES!



#396 J-BRAKE
10'-6"
\$70 DAY | \$210 WK



#395 J-BRAKE
8'-6"
\$70 DAY | \$210 WK



#394 J-BRAKE
6'-6"
\$70 DAY | \$210 WK



- #891 18' UPRIGHT
- #892 24' UPRIGHT
- #895 6' UPRIGHT BRACKET

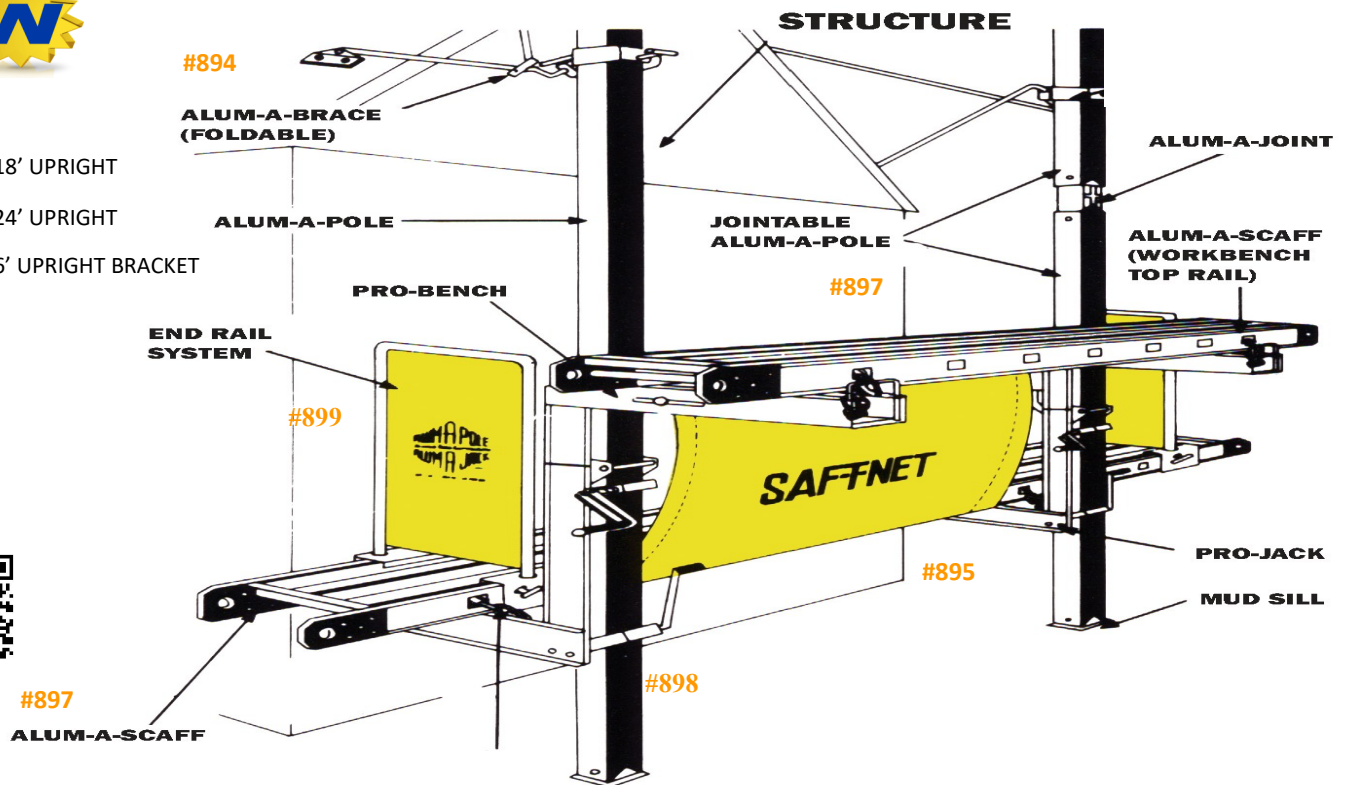

		DAY	WEEK
#890	24' H X 24' W KIT	\$145	\$290
#891	18' UPRIGHT BY THE PIECE	\$17	\$51
#892	24' UPRIGHT	\$17	\$51
#893	6' UPRIGHT	\$12	\$36
#894	BRACE "ABF"	\$6	\$18
#895	PROJACK "AP"	\$17	\$51
#896	PROBENCH BRACKET "APB"	\$6	\$18
#897	24' ALUM-A-SCAFFOLD 14"	\$46	\$138
#898	SAF-T-NET 22'	\$12	\$36
#899	ENDRAIL SAFETY SYSTEM	\$6	\$18



#273



INTERIOR SCAFFOLD		DAY	WEEK
#279	6' X 30" X 6' PRO-JAX	\$40	\$100
#289	6' X 30" X 3' PRO-JAX 1/2 SECTIONS	\$15	\$30
#273	6' GUARDRAIL KIT	\$20	\$50
#274	PRO-JAX OUTRIGGER	\$18	\$36

PIPE SCAFFOLD		WEEK	MONTH
#500	5'X5' END FRAME	\$7	\$21
#526	5'X6'4" MASON END FRAME	\$9	\$27
#501	7' CROSS BRACE	\$1	\$3
#504	LEVELING JACK	\$6	\$18
#527	BASE PLATE	\$1	\$3
#505	8" CASTER WHEEL	\$7	\$21
#503	CATWALK 7' X 20"	\$10	\$30
#506	SIDE ARM 20"	\$7	\$21
#524	OUTRIGGER	\$7	\$21
#507	WELL WHEEL	\$20	\$60
#509	WELL WHEEL HOIST ARM	\$13	\$39
#536	GUARD RAIL 5' END	\$13	\$39
#537	GUARD RAIL 7' SIDE	\$8	\$24
#539	GUARD RAIL MID POST	\$8	\$24
#515	DIAGONAL BRACE 7'	\$7	\$21
#538	TOE BOARD	\$8	\$24

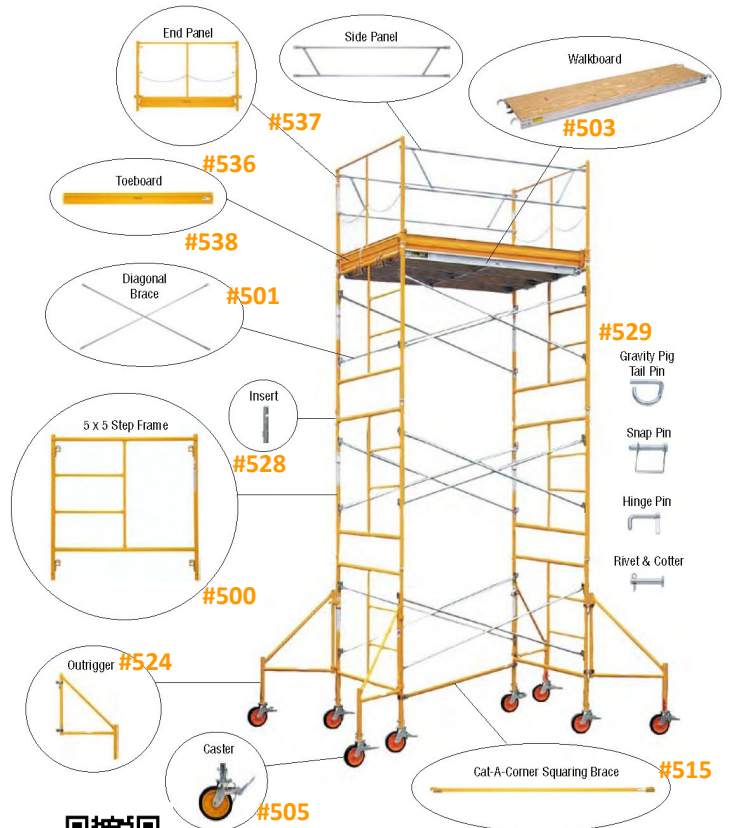

#2502 SCAFFOLD STAIR KIT
CALL FOR DETAILS

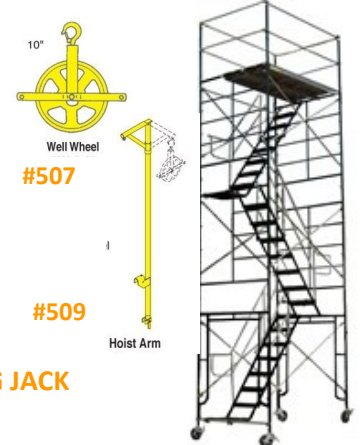
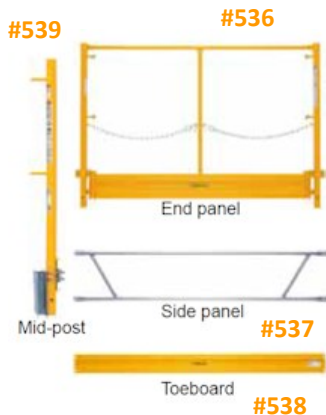

914-592-2016 | 914-739-9000
OPEN MONDAY - SATURDAY 7 TO 5

NO TRUCK? NO TIME?
NO PROBLEM! WE DELIVER!

LADDERS

STEP LADDERS - T1A FIBERGLASS		DAY	WEEK
#128	8'	\$22	\$66
#133	12'	\$26	\$75
#517	16'	\$50	\$150
#880	20'	\$66	\$198
#332	LITTLE GIANT ADJUSTABLE LADDER	\$30	\$90
4' FT TO 7' STEP / 9' TO 15' EXTENSION			



#132 LADDER BRACKET



#332



Aluminum Pick

#511	12" X 24'	\$46 DAY	\$138 WK
#510	20" X 16'	\$30 DAY	\$90 WK
#513	20" X 24'	\$46 DAY	\$138 WK

#127 LADDER STABILIZER



CALL TODAY FOR MONTHLY RATE!

EXTENSION LADDERS -T1A		DAY	WEEK
#129	24' ALUMINUM	\$30	\$90
#131	32' ALUMINUM	\$35	\$105
#130	40' ALUMINUM	\$50	\$150
#516	60' ALUMINUM	\$90	\$360
#127	LADDER STABILIZER	\$9	\$18
#132	LADDER BRACKET	\$11	\$22



**WE STOCK NEW
PRESSURE WASHERS
FOR SALE & RENT**



#378 PRESSURE WASHER HOT WATER
1,500 PSI | 2.6 GPM | ELECTRIC
\$110 DAY | \$440 WK



#379 PRESSURE WASHER HOT WATER
3,500 PSI | 4.7 GPM | GAS
\$180 DAY | \$720 WK



#540 PRESSURE WASHER
6,000 PSI | 3.7 GPM | GAS
\$230 DAY | \$920 WK



#376 PRESSURE WASHER
4,000 PSI | 3.5 GPM | GAS
\$116 DAY | \$464 WK



#375 PRESSURE WASHER
3,000 PSI | 4 GPM | GAS
\$92 DAY | \$368 WK



#369 PRESSURE WASHER
2,000 PSI | 3.0 GPM | GAS
\$72 DAY | \$288 WK

Most Popular

**Soap Injectors
Extension Wands
Turbo Tips
Cleaners & Soap
& So Much More!
Sold @ WTR**

Extension Wand!



**#377 EXTENDED REACH
WAND ADJUSTABLE TO 18'
\$20 DAY | \$60 WK**



**#622 SURFACE CLEANER
20" | PUSH | ATTACHMENT
\$30 DAY | \$90 WK**



**#374 PRESSURE WASHER
1,200 PSI | 110 V ELECTRIC
\$60 DAY | \$240 WK**



914-592-2016 | 914-739-9000
OPEN MONDAY - SATURDAY 7 TO 5

**NO TRUCK? NO TIME?
NO PROBLEM! WE DELIVER!**

PIPE WRENCH



#169 PIPE THREADER
1/4" - 2" | ELECTRIC
\$90 DAY | \$360 WK



#350 PIPE & DIE SET
1/4" - 2"
\$25 DAY | \$50 WK



#616 POWER THREADER
1/2" - 2" | HAND HELD | ELEC
\$57 DAY | \$228 WK



#164	2'	\$11 D	\$22 W
#163	3'	\$13 D	\$26 W
#163L	4'	\$13 D	\$26 W



#160 PLUMBERS PIPE STAND | VISE | 1/2" - 4"
\$17 DAY | \$34 WK



#161 - 1/2" - 4" PIPE CUTTER
\$13 DAY | \$26 WK



#162 - 4" PIPE CUTTER
\$25 DAY | \$75 WK



#166 CAST IRON PIPE CUTTER
\$40 DAY | \$160 WK



#619 PEX EXPANSION TOOL
1/2" - 3/4" - 1"
\$40 DAY | \$160 WK



#618 PROPRESS
1/2" - 3/4" - 1" - 1-1/4"
\$125 DAY | \$375 WK



#1600 PROPRESS
1/2' - 3/4" - 1-1/2" - 2"
\$200 DAY | \$600 WK



#1602 PROPRESS JAW ACCESSORY KIT
2-1/2" - 3" - 4"
\$150 DAY | \$375 WK

CALL TODAY FOR MONTHLY RATES!

**CALL TODAY
FOR MONTHLY
RATES!**

**WE STOCK
CABLES**



#168 PIPE THAWER
110 VOLT | 400 AMP
\$176 DAY | \$528 WK



#352 PIPE FREEZE KIT 3/8"-3"
CO2 TANK ADDITIONAL
\$40 DAY | \$160 WK



#354 SNAKE 50'
1" - 3" | ELECTRIC | VSR
\$50 DAY | \$200 WK



#349 SEWER SNAKE 75'
AUTO-FEED | UP TO 3" DIAM.
\$92 DAY | \$368 WK



*Extends
up to 120'*

*Additional Cables
Available*

#215 SEWER SNAKE 50'
2" - 4" SECTIONAL CABLES
\$92 DAY | \$368 WK



#351 DRAIN SNAKE 25'
1" - 3" | ELECTRIC | VSR
\$44 DAY | \$176 WK



#608 CAMERA LOCATOR
FOR #606 & #607 CAMERA
\$60 DAY | \$240 WK



#606 INSPECTION CAMERA
200' | COLOR HEAD | SELF LEVEL
\$275 DAY | \$963 WK



#300 HYDROSTATIC PUMP
GAS POWERED
\$88 DAY | \$352 WK



#301 HYDROSTATIC TEST PUMP
ELECTRIC | 110 VOLT
\$94 DAY | \$376 WK



#269 WATER JET KIT 100'
CLEANS 1-1/2" TO 4" DRAIN
1,500 PSI | 1.76 PM
\$120 DAY | \$480 WK

PLUMBING EQUIPMENT



914-592-2016 | 914-739-9000
OPEN MONDAY - SATURDAY 7 TO 5

**NO TRUCK? NO TIME?
NO PROBLEM! WE DELIVER!**

CALL TODAY FOR MONTHLY RATE!

#40 ROTARY HAMMER *
 DRILL 2" CAP | SDS
\$80 DAY | \$320 WK



#94 DEMOLITION *
 HAMMER 68 LB | 1-1/8"
\$100 DAY | \$395 WK



#95 PAVEMENT BREAKER *
 HAMMER | 28 LB | HILTI TE
\$90 DAY | \$360 WK



#90 DEMOLITION *
 HAMMER 50 LB | HILTI BITS
\$80 DAY | \$320 WK



#42 GRINDER *
 RIGHT ANGLE | 7 - 9"
\$22 DAY | \$66 WK



#41 GRINDER *
 RIGHT ANGLE | 4"
\$18 DAY | \$36 WK



#39 HAMMER DRILL *
 SDS PLUS | VSR
\$23 DAY | \$69 WK



#91 ROTARY HAMMER *
 DRILL 1-1/2" CAP | SDS
\$55 DAY | \$220 WK



#222 BAND SAW
 3-1/4" CAP | VS
\$23 DAY | \$92 WK



#634 DEEP CUT BAND
 4-3/4" CAP | VS
\$29 DAY | \$116 WK



#361 CHOP SAW *
 14" BLADE
\$30 DAY | \$120 WK



#74 MAGNETIC DRILL PRESS
 1/2" CHUCK
\$72 DAY | \$286 WK



#211 SAWZALL *
VARIABLE SPEED
\$18 DAY | \$36 WK



#209 CIRCULAR SAW *
7-1/4" BLADE
\$18 DAY | \$36 WK



#208 WORM DRIVE SAW *
7-1/4" BLADE
\$22 DAY | \$44 WK



#202 JIG SAW *
VARIABLE SPEED
\$18 DAY | \$36 WK



#206 ELECTRIC PLANER
3 -1/4" BLADE
\$33 DAY | \$66 WK



#212 ROUTER
1/4" COLLET VS | PLUNGE BASE
\$18 DAY | \$36 WK



#221 COMPOUND MITER * *
SAW 12" BLADE
\$44 DAY | \$176 WK



#219 SLIDING COMPOUND* *
MITER SAW 12" BLADE
\$46 DAY | \$184 WK



#423 DRILL 20V
BATTERY OPERATED VSR
\$18 DAY | \$54 WK



#213 SCREW GUN *
VSR | ELECTRIC
\$18 DAY | \$36 WK



#210 TABLE SAW *
10" BLADE
\$50 DAY | \$200 WK



#636 JAMB/UNDERCUT *
SAW 6-1/2" BLADE
\$29 DAY | \$116 WK



#220 HOLE HAWG
1/2" JOIST DRILL
\$28 DAY | \$84 WK



#60 DRILL *
1/2" RIGHT ANGLE | VSR
\$18 DAY | \$36 WK



#61 DRILL *
1/2" | D-HANDLE | VSR
\$18 DAY | \$36 WK



#635 TOE KICK SAW *
3/4" CUT
\$29 DAY | \$116 WK



914-592-2016 | 914-739-9000
OPEN MONDAY - SATURDAY 7 TO 5

NO TRUCK? NO TIME?
NO PROBLEM! WE DELIVER!

CALL TODAY FOR MONTHLY RATE!



#199 BELT SANDER *
4" X 24" | VARIABLE SPEED
\$18 DAY | \$36 WK



#198 BELT SANDER *
3" X 21" | VARIABLE SPEED
\$18 DAY | \$36 WK



#223 PALM SANDER
\$13 DAY | \$26 WK



#200 DISC 7" SANDER *
\$18 DAY | \$36 WK



#299 BUFFER
7" | VARIABLE SPEED
\$18 DAY | \$54 WK



#217 HEAT GUN
500° - 750° F
\$18 DAY | \$36 WK



#841 FINISH NAILER
20V | ANGLED | 230' RANGE
\$40 DAY | \$120 WK



#840 FRAMING NAILER
CORDLESS | 20 V
\$69 DAY | \$277 WK



#66 ROOFING NAILER *
3/4"-1-3/4" COIL NAIL
\$29 DAY | \$116 WK



#346 SIDING NAILER *
1-1/2" - 3" COIL NAIL
\$29 DAY | \$116 WK



#270 1" CROWN STAPLER
PNEUMATIC LATHING
\$29 DAY | \$87 WK



#344 BRAD NAILER *
5/8"-2-1/8" 18 GA BRADS
\$20 DAY | \$60 WK



#63 FINISH NAILER *
1-1/4" - 2 1/2" 20 GA STAPLE
\$29 DAY | \$116 WK



#64 FRAMING NAILER *
STICK | 6-16D
\$29 DAY | \$116 WK



541 GPM

#304 TRASH PUMP
4" | PORTABLE | GAS
\$95 DAY | \$380 WK



383 GPM

#303 TRASH PUMP
3" | PORTABLE | GAS
\$75 DAY | \$300 WK



163 GPM

#302 TRASH PUMP
2" | PORTABLE | GAS
\$57 DAY | \$228 WK



29 GPM

#185 PUMP
1" CENTRIFUGAL | GAS
\$35 DAY | \$140 WK



88 GPM

#186 DIAPHRAGM PUMP
3" PORTABLE | GAS
\$70 DAY | \$280 WK



Submersible

79 GPM

#311 TRASH PUMP 2"
ELECTRIC | 110 VOLT
\$40 DAY | \$160 WK



Submersible

89 GPM

#312 PUMP 2"
ELECTRIC | 110 VOLT
\$40 DAY | \$160 WK



Submersible

121 GPM

#313 PUMP 3"
ELECTRIC | 110V | 220V
\$92 DAY | \$368 WK



DISCHARGE HOSE

- #704 | 3/4" X 50' | \$9 DAY
- #705 | 2" X 50' | \$12 DAY
- #706 | 3" X 50' | \$14 DAY
- #707 | 4" X 50' | \$18 DAY



SUCTION HOSE

- #708 | 2" X 20' | \$11 DAY
- #709 | 3" X 20' | \$13 DAY
- #716 | 4" X 20' | \$17 DAY



Submersible

#182 PUMP
3/4" SUBMERSIBLE
\$18 DAY | \$36 WK



#307 FLOOD SUCKER
VACUUM & PUMP
\$69 DAY | \$276 WK

We Stock NEW
Pumps, Hoses & Fittings

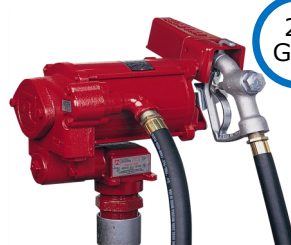

20 GPM

#448 FUEL TRANSFER PUMP
110 VOLT
\$40 DAY | \$140 WK



28 GPM

#545 FUEL TRANSFER PUMP
110 VOLT
\$60 DAY | \$240 WK



914-592-2016 | 914-739-9000
OPEN MONDAY - SATURDAY 7 TO 5

NO TRUCK? NO TIME?
NO PROBLEM! WE DELIVER!

MISC.



#124 FLOOR JACK
3 TON
\$23 DAY | \$69 WK



#362 TRANSMISSION JACK
2,000 LB. CAPACITY
\$57 DAY | \$228 WK



#62 ENGINE CRANE
1,500 LB. CAPACITY
\$54 DAY | \$216 WK



#280 AIRLESS PAINT SPRAYER | .54 GPM
\$100 DAY | \$400 WK



#356 HVLV SPRAY GUN KIT
\$85 DAY | \$340 WK



#277 LINE STRIPER *
AEROSOL
\$18 DAY | \$36 WK



#410 PORTA POWER KIT
10 TON
\$44 DAY | \$176 WK



#409 PORTA-POWER
4 TON KIT
\$33 DAY | \$132 WK



#21 IMPACT WRENCH 3/4"
ELECTRIC
\$29 DAY | \$116 WK



#20 IMPACT WRENCH 1/2"
ELECTRIC
\$23 DAY | \$96 WK



#203 BATTERY CHARGER
\$28 DAY | \$112 WK



#9030 GREEN MONSTER
STAKE PULLER HYDRAULIC
\$110 DAY | \$440 WK



#555 HOPPER
1 CUBIC YARD SELF DUMP
\$33 DAY | \$99 WK



#257 WALLPAPER STEAMER
ELECTRIC
\$35 DAY | \$140 WK



#416 PAPER SHREDDER
\$65 DAY | \$260 WK

DAILY • WEEKLY • MONTHLY

MISC.



#69 CABLE PULLER
2,000 LB CAP.
\$18 DAY | \$54 WK



#436 SUCTION CUP 6"
\$17 DAY | \$34 WK



#438 STRAPPING TOOL KIT
1/2" & 5/8" CAP.
\$18 DAY | \$54 WK



#414 ROLLING MAGNET 25"
"MAGNETIC BROOM"
\$17 DAY | \$51 WK



#265 WHEELBARROW
8 CU. FT. - FLAT FREE TIRES
\$13 DAY | \$26 WK



#419 METAL DETECTOR
"ACE 250 SPORT"
\$29 DAY | \$116 WK



#32 BOLT CUTTERS
MANUAL
\$18 DAY | \$36 WK



#214 COMPOSITE
SHINGLE CUTTER
\$28 DAY | \$84 WK

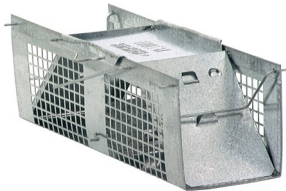

#276 HAVE-A-HART TRAP
\$17 DAY | \$34 WK



#548 WATER TANK
300 GALLON
\$33 DAY | \$66 WK



#2040 FIRE EXTINGUISHER
NO. 10 ABC (PLUS RECHARGE)
\$17 DAY | \$34 WK

#1530 MAN HOLE LIFT
CONFINED SPACE LIFT
\$85 DAY | \$340 WK

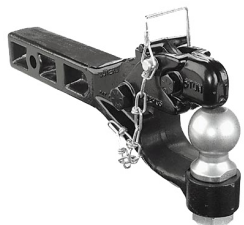

#114 PINTLE HOOK
BALL COMBO HITCH
\$15 DAY | \$30 WK



#530 FOLDING RAMPS
1,000 # CAPACITY
\$23 DAY | \$92 WK

**CALL
TODAY FOR
MONTHLY
RATES!**



914-592-2016 | 914-739-9000
OPEN MONDAY - SATURDAY 7 TO 5

NO TRUCK? NO TIME?
NO PROBLEM! WE DELIVER!



#82 WELDER
300 AMP | DIESEL
\$154 DAY | \$616 WK

**WE SELL
WELDING GLOVES
SUPPLIES
SO MUCH MORE!**



#262 AKC WELDER
100 AMP | GAS
\$66 DAY | \$264 WK



#261 MIG WELDER
110 VOLT | GAS OPTIONAL
\$46 DAY | \$184 WK



#266 PLASMA CUTTER
110/220 VOLT | 3/8" CAP
\$69 DAY | \$276 WK



#222 BAND SAW*
3-1/4" CAP. | VARIABLE SPEED
\$23 DAY | \$92 WK

BLADES SOLD SEPERATELY



#41 RIGHT ANGLE GRINDER *
4" | ELECTRIC
\$18 DAY | \$36 WK



**#42 RIGHT ANGLE *
GRINDER 7" - 9"**
\$22 DAY | \$66 WK



#28 ACETYLENE TORCH KIT
\$33 DAY | \$132 WK

TANKS NOT AVAILABLE



**#634 DEEP CUT BAND*
SAW 4-3/4" CAP**
\$29 DAY | \$116 WK



**#74 MAGNETIC DRILL
PRESS | 1/2" CHUCK**
\$72 DAY | \$286 WK



#361 CHOP SAW *
12" BLADE
\$30 DAY | \$120 WK



**#630 METAL CIRCULAR
SAW 8" | ELECTRIC**
\$20 DAY | \$80 WK

**CALL FOR
MONTHLY
RATES
TODAY!!**

BEST SELLING ACCESSORIES AND SUPPLIES IN STOCK!



DIAMOND BLADES



WHEELBARROWS
ASSEMBLED



BROOMS, PICKS &
SHOVELS



SLEDGE HAMMERS

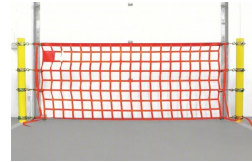

SAFETY FENCE
4' X 100'



QUIKRETE
PRODUCTS



RATCHET BINDERS



TOOL KIT



TIE DOWN STRAPS



NYLON SLINGS



COMBO HITCHES
& PINTLE HOOKS



TOWING
ACCESSORIES



RAIN GEAR



SAFETY APPAREL



HAND TOOLS



ASSORTED GLOVES



MARKING PAINT &
MORE



TRAFFIC SAFETY
SUPPLIES



ROCK BITS
& DRILL STEEL



POINTS & CHISELS
ASPHALT CUTTERS



HAMMER DRILL BITS
SPLINE & SDS



AIR & WATER HOSES



OIL AND FUEL
FILTERS



FUEL MIXES AND OILS



HYDRAULIC OIL
AW 32 & 46



HYDRAULIC HOSES
MADE HERE



GREASE GUNS



ASSORTED MASON
TOOLS



ABRASIVE CUTTING &
GRINDING BLADES



GET 10 REFILLS AND
THE NEXT IS ON US

We Sell, Service and Repair Your Favorite Brands



914-592-2016 | 914-739-9000
OPEN MONDAY - SATURDAY 7 TO 5

NO TRUCK? NO TIME?
NO PROBLEM! WE DELIVER!

PARTY LINE

partylinerentals.com • 914-592-1200

Visit our Store. *Come and Explore*



Climate Control

Event Layout ♦ On-Site Technicians & Service Available 24/7

Life just got easier with our complete party packages for 20 to 100 guests. Tent, tables, chairs, and lighting for a value packed event.



Complete Packages for Training, Luncheons & Parties Heated & Air Conditioned Tents

Call 914-592-1200 or visit www.partylinerentals.com to rent a professionally installed tent!

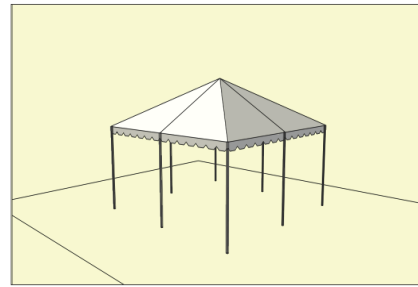

30 Guest Party Package
20'x20' Tent
#7953

- 30X
- 3X
- 1X
- 1X

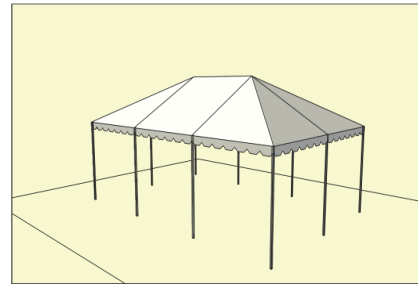

50 Guest Party Package
20'x30' Tent
#7951

- 50X
- 5X
- 1X
- 2X

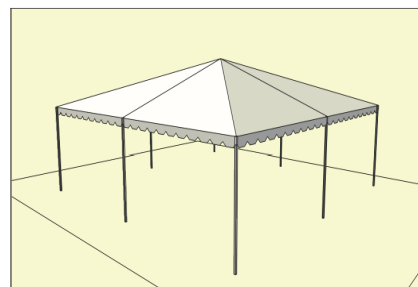

70 Guest Party Package
30'x30' Tent
#7954

- 70X
- 7X
- 2X
- 2X

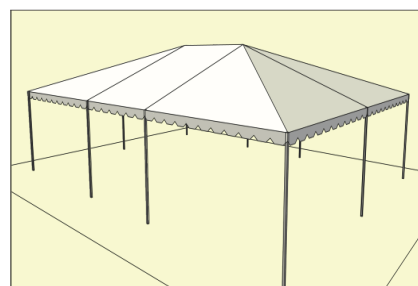

100 Guest Party Package
30'x40' Tent
#7952

- 100X
- 10X
- 2X
- 3X

PACKAGES ARE FOR RESIDENTS IN WESTCHESTER COUNTY AND GRASS SET UP ONLY. PRICE, SELECTION & AVAILABILITY ARE SUBJECT TO CHANGE. CALL FOR DETAILS. SOME EXCLUSIONS APPLY.



**P
O
P
U
L
A
R
T
E
N
T
S**

Custom Sizes Available! CALL FOR MORE INFO + PRICING!

Party Line has the largest selection of Frame, Clear Top, Sailcloth, Century, Canopies and Structures in Westchester.

Professional Tent Installations for Patios, Decks, Driveways, Lawns and Rooftops.

Popular

16x20 25x25 50x50

Sizes

16x28 25x30 50x60

10x10 16x36 20x35 50x80

10x20 16x40 30x30 50x100

12x24 16x48 30x40 60x100

12x30 18x38 30x50 60x180

12x36 20x25 30x60 80x70

14x21 20x40 40x40 80x100

14x28 20x50 40x60 80x130

14x38 20x60 40x80 80x160

14x42 20x80 40x100 80x190

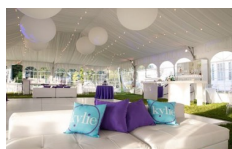

Open: Monday– Friday 8am To 5:30pm
Saturday 9am-3pm

PARTY LINE



914-592-1200



Party Line Rentals



@partylinrentals

TABLES

Rectangular

- 4' x 30" Seats 4 -6
- 6' x 24" Seats 6 -8
- 6' x 30" Seats 6 -8
- 6' x 36" Seats 6 -8
- 6' x 42" Seats 6 -8
- 8' x 24" Seats 8 -10
- 8' x 30" Seats 8 -10
- 8' x 36" Seats 8 -10
- 8' x 42" Seats 8 -10

Round

- 42" Seats 4-6
- 48" Seats 6 - 8
- 54" Seats 8 -10
- 60" Seats 8 -10
- 72" Seats 10 -12

Pedestal

- 24" Seats 4-6
- 30" Seats 6 - 8
- 36" Seats 8 -10

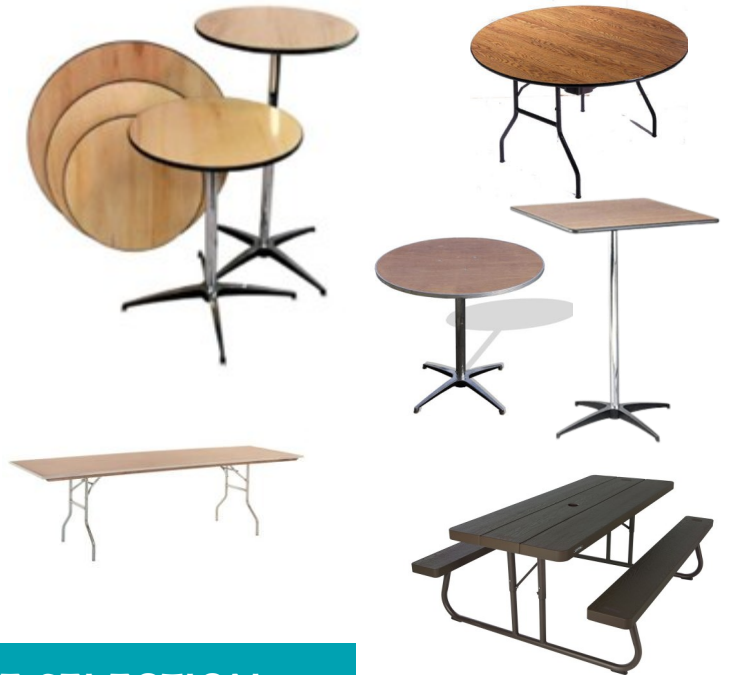

VISIT OUR WEBSITE FOR MORE SELECTION

LINENS

CHAIRS

Garden Chairs



Folding Chairs



Chivari Chairs



Throne Chairs



Ghost Chairs



Chair Cushion



X20 Chairs



Specialty Seating

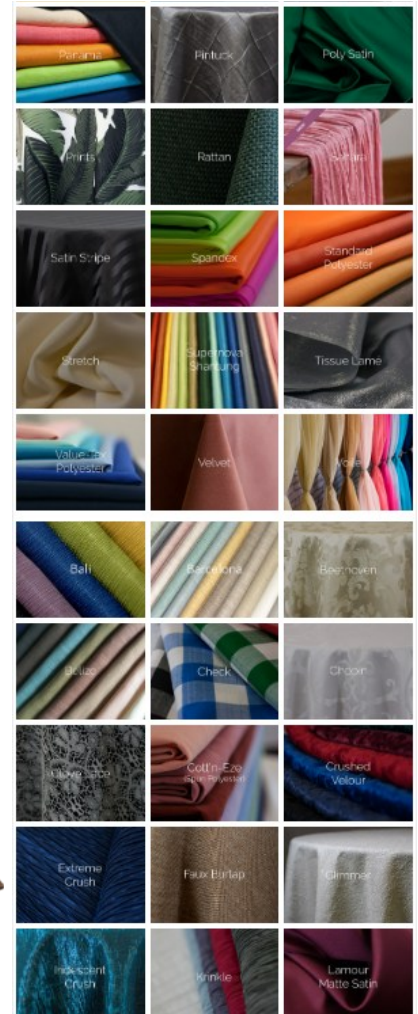

RUSTIC COLLECTION



- Farm Table 42" x 8'
- Round Farm Table 60"
- Cross Back Chair

- Cross Back Bar Chair
- Farm Bench 8"
- High Pub Table 36" x36'



Design Center: 1 Nepperhan Avenue Elmsford NY 10523 914-592-1200

STAGES

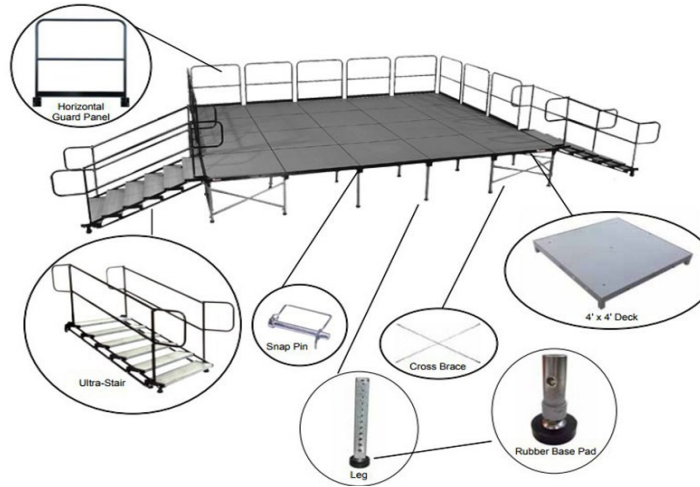

Bil-Jax Flooring System is the ideal product to use when you want to place a tent with floor in an area that has an unlevel surface! Great for Stages - Bands - Presentations - Weddings!

BARS & BARWARE

Modular Flash Bar



Pewter Bar 4' & 6'



Rolling Bar
* skirt sold separately

Ice Chest 120 QT



Ice Tongs

White Ice Tub



Ice Scooper

Bar Pitcher

Cocktail Shaker

Wine Ice Bucket
w/ Stand



BAR 6' PREMIUM WOOD PANEL BAR

DANCE FLOOR

White

Black

Checkered

Wood



**All Sizes Available
Call For More Information!**

CHINA

DINNERWARE

DRINKWARE

FLATWARE

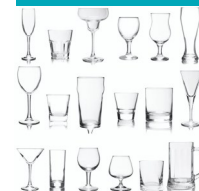

GRILLS

BBQ Charcoal 2'x3'



BBQ Charcoal 2'x5'



BBQ Charcoal w/ Electric Rotisserie



BBQ Propane 2'x6'

** propane sold separately



BBQ Propane 2'x42"

** propane sold separately

Aluminum Cooktop Tent
6' X 10'

Propane Tanks

20# - 40# - 60# - 100#

Propane Deep Fryer 40#

** propane sold separately

Table Top Deep Fryer

Electric | 110V

Check out the website for our full line of cooking equipment, appliances, pots & pans and more.

Picnic Tables with Benches



Patio Umbrella



O
U
T
D
O
O
R

9ft Market Umbrella



11 ft Market Umbrella



D
I
N
I
N
G

Rhino Patio Heater



Lava Light



FILM & PRODUCTION

Directors Chair W/ Tray

Bull Horn

Hair & Makeup Chair

Makeup Mirrors

Red Carpet

8' Red/Black Rope

Stanchion w/ Retractable

Stanchion Chrome

Ceremonial Scissors



We offer an extensive line of gas and electric powered climate control rental items.



HEATING & COOLING

A/C Units

Barricades

Generators

Heaters

Light Towers

Pedestal Fans



Design Center: 1 Nepperhan Avenue Elmsford NY 10523 914-592-1200

CONCESSION & KIDS

Popcorn & Popper Machine

Popcorn & Popper Cart

Cotton Candy Machine

Cotton Candy Cart

Sno-Cone Machine

Sno-Cone Cart

Ice Cream Cart

Hot Dog Cart W/ Umbrella

Frozen Drink Machine

Funnel Cake Machine



Kids Folding Chairs

Kids Chivari Chairs

Chalkboard Table

Kids Banquet Table 6'

Kids Round Table 42'



VISIT OUR WEBSITE FOR CHINA - GLASSWARE - FLATWARE!

PICK UP TODAY!



Solid and pattern table covers are available in various colors, sizes and shapes.



Plastic cutlery, plates and cups available



Popcorn, cotton candy, sno-cone, frozen drinks, funnel cake and more!



We sell cook pans/lids, trays and sternos.



Open: Monday- Friday 8am To 5:30pm
Saturday 9am-3pm

PARTY LINE



914-592-1200

Party Line Rentals

@partylinerentals

3 GENERATIONS OF FAMILY OWNED BUSINESS

Westchester Tool Rentals offers a comprehensive Tool & Equipment Rental and Retail inventory while providing the best personalized customer service not only for municipalities and the big contractor but also for the homeowner and 'do-it-yourselfer'. Family owned and operated, WTR has been serving the community for over 36 years, and just like an old fashion general store, we probably have what you need, but if we don't we'll be more than happy to find it for you. We are proud to be recognized as one of the top Rental Supply Houses in the NY Metro Region as well as being highly regarded in the rental industry nationally.

Tools have always been in the Puff blood. We had our first garage and tool rental store in Silver Lake, White Plains NY. WTR now includes 2 locations in Elmsford and Peekskill, NY with over 36,000 sq feet of tools and equipment. In 1990, the tool-rental business diversified into the party-rental biz, creating a sister company, Party Line Tent Rentals. The result is that Party Line is much more than just tents: It supplies generators, air-conditioners, cooking equipment, China table-top, and chairs, as well.



Buddy, Kenny & Ben Puff



The Puff family first garage and tool rental in Silver Lake, White Plains NY



**WTR is proud to be a
Women Led Business Enterprise
led by Karin Puff, President.**



A Whole Lot More Than a Rental Store

Rentals - Sales - Service

FILL UP

**Propane and Kerosene
Filling Station**



REPAIR & SERVICE



**Hydraulic Hoses, Fittings, Adapters & Custom Made
Hydraulic Hose Assemblies**



Express Hose Center

WTR WESTCHESTER TOOL RENTALS

wtrrentals.com

Rentals • Sales • Service

ORIGINAL LOCATION—1983



ELMSFORD LOCATION—1989



PEEKSKILL LOCATION—2015



Why Buy when you can
Rent and **SAVE?**
We also **Sell** NEW and USED
Equipment if you want to
Buy!

Serving the NY Tri-State from
Northern and Central
Westchester.

Quality Products. Competitive
Prices. Professional Service.

Family Owned since 1983



11 Vreeland Ave Elmsford 914-592-2016
1075 Washington St Peekskill 914-739-9000