

A	19'8"	I	6'11"
B	6'4"	J	4'4"
C	8'11"	K	4'1"
D	7'3"	L	9"
E	2'3"	M	2'6"
F	8'6"	N	8"
G	1'8"	O	6"
H	1'6"	P	4'3"

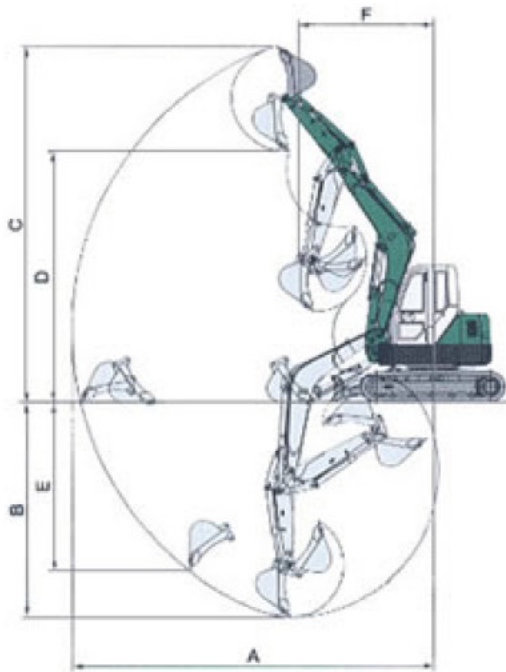

A	Max Digging Radius	23'4"
B	Max Digging Depth	15'1"
C	Max Digging Height	22'9"
D	Max Dumping Height	14'3"
E	Max Vertical Digging Depth	10'10"
F	Min Front Turning Radius	8'5"
	At Right Boom Swing	7'3"
	Digging Force	14,730 lbs

### Basic Specifications

Canopy	4 Post/Cabin
Bucket Capacity	8.8 cu. Ft.
Operating Weight	18,100 lbs
Transports Weight	17,635 lbs

### Hydraulic Equipment

Pumps	4
Type-Piston/Gear	2 Piston / 2 Gear
Total Flow	51.8 gpm
Operating Pressure	3,550 psi
Auxilliary Flow	18.9 gpm

### Engine

Model	Isuzu AA-4JG1
Horsepower	56.3 @ 2,100 rpm
Fuel Tank Capacity	18.5 gals

### Dimensions

Length	19'8"
Width	7'3"
Height	8'5"

### Features

Travel Speed L/H	1.6/2.7 mph
Ground Pressure	5.2 psi
Swing Speed	9.2 rpm
Swing Angle	L50 /R80